

**REPUBLIC OF RWANDA**

**ULK POLYTECHNIC INSTITUTE**

**P.O Box 2280 Kigali**

**Website://www.ulkpolytechnic.ac.rw**

**E-mail: polytechnic.institute@ulk.ac.rw**

**ACADEMIC YEAR 2023 – 2024**

**DEPARTMENT OF CIVIL ENGINEERING**

**OPTION: CONSTRUCTION TECHNOLOGY**

**RENOVATION OF KANGO BRIDGE**

**Case study: GABON, ESTUAIRE PROVINCE – KANGO SECTOR**

Final year project submitted in partial fulfilment of the requirements for the award of  
advanced Diploma in Civil Engineering (A1)

**Presented by:**

**OBONO MBEANG Sarah, Roll number: 202150190**

**Under the Guidance of Ir. ISHAMUNDA IGNACE**

**Kigali, October 2024**

## **DECLARATION**

This research study is my original work and has not been presented for a degree or any other academic award in any University or Institution of Learning. No part of this research should be reproduced without the authors' consent or that of ULK Polytechnic Institute.

Student name: OBONO MBEANG Sarah

Sign: \_\_\_\_\_

Date: \_\_\_\_\_

## **CERTIFICATION**

I confirm that the work reported in this research project was carried out by the candidate under my supervision and it has been submitted with my approval as the UPI supervisor.

Name: ISHAMUNDA IGNACE

Signature: \_\_\_\_\_

## **DEDICATION**

It is from the depths of my heart and with great pleasure that I dedicate this work:

### **To my dear parents:**

**MBEANG ESSONO Robert and VINGA Marie-Brigitte Who** have always pushed me, motivated me and supported me in my studies. Without them, I certainly wouldn't be here today. This end-of-studies project is therefore the culmination of the sacrifices made, the support and the encouragement they have given me throughout this journey. I therefore express my love, respect and gratitude to them. I hope to be able to meet one of their expectations today and to be up to the task in order to make them proud one day. I wish them a long life.

### **To my sisters:**

**NGANBANI LAURINE, MENGUE MBEANG Marielle, NTSAME NGUEMA Ivane Faustin and BANGA Jenny Ophelia** as a sign of love, recognition and gratitude for the dedication, support and sacrifices they have always shown to me. May GOD safeguard our family attachment and fill you with happiness throughout your life.

### **To my niece and friend:**

**LELO Léagrâce** Who has never ceased to support me and to whom no words can express my gratitude and loyalty. I wish her a long life full of success and happiness.

### **To all my friends:**

**ESSOULA N'NA Orlane, MOUCKANI Ness, Carmela, MPANIA Patricia and NTSAME ESSA Grace Siguelaine** for the love and support they have shown me during this journey.

### **To my partner:**

**OYIBA Lucrèce Esther** has always been there for me during almost my entire stay in Rwanda. I thank her for her moral support, patience, motivation and encouragement throughout this work. I wish her a long life full of success and happiness.

## **ACKNOWLEDGEMENTS**

I am grateful to God for keeping me to this day. For allowing all of this to come to fruition, for always accompanying me at every step of my life. To this university which welcomed and guided me during my years of learning, to my hod who was like a second mother to me and to all the students here. To all the polytechnic professors who, during these years of learning, have been our guides by offering us knowledge worthy of the name. Finally, to my supervisor who took his time and energy to ensure this work was successfully completed.

## ABSTRACT

The Kango Bridge, an essential infrastructure for local and regional transportation, has suffered significant deterioration over the years due to aging materials and environmental conditions. This study addresses the urgent need for its renovation, emphasizing the use of reinforced concrete techniques to ensure long-term durability and safety. The problem statement focuses on the structural weaknesses observed in the bridge, including cracks, corrosion of steel reinforcements, and reduced load-bearing capacity, which pose significant risks to users.

The main objective of this study is to propose an efficient and cost-effective renovation plan for the bridge, ensuring compliance with modern engineering standards and extending its service life. To achieve this, a comprehensive assessment of the existing structure was conducted, including material testing and structural analysis. The methods involved non-destructive testing techniques, load capacity calculations, and design simulations for the proposed reinforcement strategy.

The results demonstrated that  $H = H_1 - H_2 = 0.6$  m and a constant  $K = 100$ . This relationship indicates that for every meter of height difference, the span increases by 100 meters., combined with improved drainage and protection measures, would significantly enhance the bridge's performance.

In conclusion, the proposed renovation plan addresses the critical issues faced by the Kango Bridge and offers a sustainable solution to prevent future deterioration. Recommendations include regular maintenance schedules, continuous monitoring, and further research into innovative materials for infrastructure projects.

**Keywords:** Kango Bridge, renovation, bridge maintenance, infrastructure rehabilitation.

## TABLE OF CONTENTS

DECLARATION .....	i
CERTIFICATION .....	ii
DEDICATION.....	iii
ACKNOWLEDGEMENTS.....	iv
ABSTRACT.....	v
TABLE OF CONTENTS.....	vi
LIST OF FIGURES .....	ix
LIST OF SYMBOLS AND ABBREVIATIONS .....	x
<b>CHAPTER 1: GENERAL INTRODUCTION.....</b>	<b>1</b>
1.0 Introduction to the study .....	<b>1</b>
1.1 Background of the study .....	1
1.2 Statement of problem.....	2
1.3 Purpose of the study.....	3
1.4 Research Objectives.....	4
1.4.1 Main Objective.....	4
1.4.2 Specific objectives .....	4
1.5 Research questions.....	4
1.6 Scope and limitations.....	4
1.7 Significance of the study.....	5
1.8 Organization of study.....	5
<b>CHAPTER 2: LITERATURE REVIEW .....</b>	<b>7</b>
2.0 Introduction.....	7
2.1 Concepts, options, ideas from Authors/Experts.....	7
2.1.1 Definitions of Keys concepts .....	7
2.1.2 Opinions.....	8
2.1.3 Ideas from experts.....	8
2.2 Theoretical perspectives.....	8
2.2.1 Architectural Design of Bridge .....	8
2.2.2 Types of Architectural Design .....	9
2.2.3 Structure parts of Bridge.....	10
2.2.4 Types of Bridge according to their Structures .....	14
2.2.5 Main Materials used to Build a Bridge.....	18
2.2.6 Concrete .....	18

2.3 Steel.....	20
2.4 Surveying data and dumpy level.....	22
<b>CHAPTER 3: MATERIALS AND METHODS .....</b>	<b>24</b>
3.0 Introduction.....	24
3.1 Description of the study Area .....	24
3.2 Data collection .....	25
3.2.1 Setting the dumpy level .....	25
3.2.2 Data Analysis .....	25
3.3 Architectural design .....	25
3.4 Research from other Literature .....	26
<b>CHAPITRE 4: RESULTS AND DISCUSSIONS .....</b>	<b>27</b>
4.0 Introduction.....	27
4.1 Compressive Strength and Status of the Existing Bridge .....	27
4.1.1 Compressive Strength of Concrete Elements .....	27
4.1.2 Structural Condition of the Existing Bridge .....	27
4.2 Traffic Count.....	28
4.3 Structural Measurements .....	29
4.3.2 Historical Research .....	30
4.4 Results.....	30
4.4.1 Traffic Count.....	30
4.4.2 Structural Measurements .....	30
4.4.3 Water Level.....	30
4.4.4 Material Composition .....	30
4.4.5 Age of the Bridge.....	31
4.5 The results from estimated the bridge span using dumpy level.....	31
4.6 Renovation Techniques and Materials for the New Beam Bridge .....	32
4.6.1 Renovation Techniques.....	32
4.6.2 Materials for the New Beam Bridge .....	32
4.7 Methodology applied to find data .....	33
4.8 Top view of the Bridge or Plan View .....	27
4.9 Production of the architectural drawing.....	29
4.9.1 Top view of the Bridge or Plan View .....	29
4.9.2 Production of the architectural drawing.....	33
<b>CHAPTER 5: CONCLUSION AND RECOMMENDATIONS .....</b>	<b>36</b>
5.1 Conclusion .....	36



5.2 Recommendations.....	36
REFERENCES .....	38
<b>APPENDICES</b> .....	39

## LIST OF FIGURES

Figure 2.1: perspective of a bridge is.....	9
Figure 2.2: a typical example of a bridge abutment.....	10
Figure 2.3: pier and its parts .....	11
Figure 2.4: showing a typical detail of deck slab.....	11
Figure 2.5: beam bridge and its parts .....	12
Figure 2.7: expansion joint .....	13
Figure 2.8: bridge Railing .....	14
Figure 2.9: the types of bridge .....	14
Figure 2.10: beam bridge .....	15
Figure 2.11: truss bridge .....	15
Figure 2.12: Arch bridge.....	16
Figure 2.13: Cable-Stayed Bridge.....	17
Figure 2.14: limited state design of concrete .....	19
Figure 2.15: limited state design of concrete .....	20
Figure 2.16: limit state design of a bridge .....	21
Figure 3.1: KANGO bridge to be renovated.....	24
Figure 4.1: Methodology applied .....	26
Figure 4.2: Top view of the Bridge.....	27
Figure 4.3: structures design .....	29

## **LIST OF SYMBOLS AND ABBREVIATIONS**

AASHTO = American Association of State Highway and Transportation Officials

ArchiCAD 26: Architecture” and “Computer-Aided Design, 26 is the version of the Software

H = Upper reading minus the lower reading on the reading staff

HSLA = High-Strength Low-Alloy Steel

ISBN = The International Standard Book Number (ISBN)

K is the being a constant

LRFD stands for Load Factor Resistance Design

S = Span

UHPC = Ultra High-Performance Concrete

## **CHAPTER 1: GENERAL INTRODUCTION**

### **1.0 Introduction to the study**

This chapter focuses on the renovation of the Kango Bridge in Gabon, which is essential for the country's transportation, commerce, and connectivity. Since 2013, the bridge has shown significant wear, including a major crack that has raised safety concerns. The project aims to assess the current condition of the bridge, identify structural issues such as corrosion, foundation erosion, and concrete degradation, and propose solutions to strengthen or replace damaged components.

The chapter highlights the bridge's importance as part of National Route 1, connecting Libreville to other regions, emphasizing the economic and social impacts of its renovation. It also discusses the challenges of conducting the renovation while considering environmental factors like the river it spans and Gabon's tropical climate. The project will result in architectural drawings, topographical data collection, and an analysis of how modern design standards can be integrated into the renovation process. Overall, this chapter outlines the technical, economic, and social aspects of the renovation, underscoring its necessity for Gabon's growth and safety.

### **1.1 Background of the study**

For several years, the Kango bridge has been attracting increasing attention from the public. Indeed, since 2013, a crack has appeared across its entire width, and people are wondering what the authorities are waiting for to address this issue. Do we have to wait for it to collapse before acting? According to (SBG&P, 2019.)

The construction of the new Kango Bridge in Gabon is a major infrastructure project aimed at the bridge is part of the National Route 1, a critical route that connects Gabon's capital, Libreville, to other parts of the country and neighboring regions. It supports daily vehicular traffic, including goods transport, contributing to the economy of Gabon. The condition of the bridge is directly tied to national security, trade, and mobility. (SBG&P, 2019)

Over the years, inspections may have revealed wear and tear such as corrosion of metal parts, degradation of the concrete structure, and possibly foundation issues due to river dynamics. These concerns could pose risks to the safety of commuters, leading to the need for comprehensive renovation. (SBG&P, 2019).

Gabon's tropical climate, marked by heavy rains and high humidity, can accelerate the deterioration of infrastructure. The bridge also spans a river, which adds complexity to the

renovation due to hydrodynamic forces, potential flooding, and environmental considerations. Additionally, any renovation would need to minimize disruptions to traffic and commerce. Renovating the Kango Bridge is not only a technical necessity but also an economic priority for the region. Without proper renovation, transportation disruptions could severely impact trade, leading to increased costs for goods and services. The safety of daily commuters, who rely on the bridge, would also be a major social concern. Improving connectivity and boosting economic development in the region. Located at a strategic point, this bridge is essential to facilitate transport and trade, thus reducing logistics costs and travel times.

Gabon, rich in natural resources, needs such infrastructure to maximize its economic potential and support its growth. The Kango Bridge is part of this development perspective, by integrating into national plans to modernize infrastructure and promote regional trade. The decision to renovate is based on a cost-benefit analysis, balancing the costs of long-term maintenance versus complete replacement, while considering the need to ensure the safety and functionality of this key infrastructure for the future. (SBG&P, 2019).

## **1.2 Statement of problem**

The Second Kango Bridge is a vital infrastructure in Gabon, serving as a critical link for transportation, commerce, and connectivity in the region. Over time, the bridge has deteriorated due to factors such as age, increased traffic loads, and environmental conditions, leading to safety concerns and reduced functionality. In addition to these incidents, there is also the sea current, which undeniably has effects on the stability of the said pylons. (SBG&P, 2019).

The renovation will focus on strengthening or replacing degraded components of the bridge, such as repairing corroded steel elements and reinforcing weakened concrete. This will enhance the overall structural integrity, ensuring that the bridge can safely support the current and future traffic load without risking collapse. (Aggarwal,2004).

By addressing issues like corrosion, fatigue, and foundation erosion, the renovation will significantly extend the lifespan of the bridge. Regular maintenance and updated materials (such as corrosion-resistant coatings) will further help in minimizing future deterioration, reducing the need for frequent repairs. Indeed, the Kango bridge, which plays a crucial role in serving several Gabonese provinces, had worrying cracks. The real problem is that this bridge gets many damages in its structure's elements across the time, the main purpose of this study or the contribution of this study is to study those problems and put on the table real solutions. This study will provide result of what is damaged on the bridge and propose solution to them. (Eurocode, 2004).

### 1.3 Purpose of the study

The construction of a bridge in an urban community serves several key purposes:

- **Enhanced Connectivity:** Bridges facilitate the movement of people and goods by connecting different areas, thereby improving transportation links within the community. This connectivity is crucial for daily commutes, emergency services, and overall mobility.
- **Economic Development:** By providing efficient routes for trade and commerce, bridges can stimulate local economies. They enable easier access to markets, reduce transportation costs, and attract businesses to the area.
- **Social Interaction:** Bridges promote social cohesion by linking neighborhoods and enabling residents to engage with one another. They create opportunities for community events and gatherings, fostering a sense of belonging.
- **Recreational Opportunities:** Many bridges are designed with pedestrian walkways or viewing areas, allowing for recreational activities such as walking, cycling, or sightseeing. This enhances the quality of life for residents.
- **Urban Aesthetics:** Well-designed bridges can serve as architectural landmarks that enhance the visual appeal of a community. They contribute to the identity and character of the urban landscape.
- **Environmental Considerations:** Modern bridge projects often incorporate sustainable practices, helping to mitigate environmental impacts while providing essential infrastructure.

Overall, bridges play a vital role in urban settings by improving accessibility, supporting economic growth, and enriching community life. Connecting Communities through Infrastructure.

## **1.4 Research Objectives**

### **1.4.1 Main Objective**

The main objective of this project is to provide a general study of the existing kango bridge and provide new architectural drawing for the renovation of kango bridge located in Gabon.

### **1.4.2 Specific objectives**

The specific objective of this project report is:

1. To collect topographical data, where Kango Bridge is located using surveying tools
2. To produce the Architectural drawings of the bridge
3. To make a general study of the existing problem of the bridge
4. To provide a study that addresses these problems as solution.

## **1.5 Research questions**

- What surveying tools and methods are most effective for collecting topographical data at the Kango Bridge site?
- What architectural design principles should be applied in creating accurate and functional architectural drawings of the Kango Bridge?
- What are the primary structural and environmental issues currently affecting the Kango Bridge, and how do they impact its usability?
- What comprehensive solutions can be proposed to address the identified problems of the Kango Bridge based on current engineering and architectural practices?

By addressing these questions, we seek to gain a thorough understanding of the challenges involved and to formulate effective solutions for the renovation of the bridge.

## **1.6 Scope and limitations**

This research was carried out in Gabon, especially in Kango, which is a town in the Estuaire province of Gabon. It is situated on the Komo River and is located approximately 100 Kilometers southeast of Libreville the capital city of the country, occupying 65square kilometers in the northwestern province of Estuaire. The period of this research focused on the period of 3 months in order to get detailed and accurate information.

This project will be focus on the renovation of kango bridge situated in Gabon, this will include the study the place by taking the surveying data and producing the Architectural drawing.

As limitation of this study, the renovation of the bridge requires several additional procedures that will not be addressed in this book. These procedures include site investigation, geotechnical analysis, and structural design, which will not be discussed in this study.

### **1.7 Significance of the study**

This research will contribute on the construction of a bridge study to allow the researcher to be focused on the analyzing the socio-economic impact and technical challenges related to the construction of the new Kango Bridge in Gabon.

The research will facilitate the research to fulfill partial requirement for the award of advanced diploma of Civil Engineering in Construction Technology. The researcher will gain the opportunity to be informed about action, gather, evidence for theories construction of any kind of bridge. And also, the researcher will create networking with the population.

Additionally, the researchers may use this research as a secondary of data and basic guidelines for writing their research dissertation.

ULK, will use this research to add on its existing library materials on the challenges encountered during the planning and construction of the new Kango bridge in Gabon.

### **1.8 Organization of study**

This research is organized into five chapters:

Chapter One: Introduction

This chapter provides a comprehensive introduction, including the background of the study, the problem statement, general objectives, and specific objectives.

Chapter Two: Literature Review

In this chapter, we explore existing literature related to our topic—specifically, the renovation of the Kango Bridge. This includes an analysis of relevant publications such as journals and books that inform our research.

Chapter Three: Materials and methods

Here, we describe the methods employed to achieve our project objectives, detailing the approaches taken to gather and analyze data.

Chapter Four: Results and Discussion

This chapter presents the findings of our research and engages in a discussion of their implications in relation to our objectives.

Chapter Five: Conclusion and Recommendations



The final chapter summarizes the key insights from our research and offers recommendations based on our findings.

Through this structured approach, we aim to provide a thorough examination of the issues surrounding the renovation of the Kango Bridge.

## **CHAPTER 2: LITERATURE REVIEW**

### **2.0 Introduction**

This chapter focuses on the literature review concerning the design and concepts relevant to the renovation of the Kango Bridge. It examines various scholarly works that address surveying data collection and architectural drawing principles applicable to bridge construction, drawing insights from different authors' contributions in this field. The primary objective of this literature review is to identify gaps in existing research, thereby enhancing our understanding of the surveying data collection and architectural drawing considerations necessary for effectively renovating the Kango Bridge. By synthesizing findings from journals, books, and other relevant publications, this chapter aims to provide a comprehensive foundation for the subsequent phases of the project, ensuring that all critical aspects of bridge design and renovation are thoroughly considered.

### **2.1 Concepts, options, ideas from Authors/Experts**

#### **2.1.1 Definitions of Keys concepts**

There is no single universally accepted definition of bridge. However, we will try to explain what is to know about it.

Several authors have discussed the importance of bridges in society, and their evolution over time.

#### **Bridge**

A Bridge is a structure that allows you to cross a natural or artificial obstacle (depression, watercourse, communication route, valley, ravine, canyon) by passing over it. The crossing supports the passage of humans and vehicles in the case of a road bridge, or water in the case of an aqueduct. (Md. Safin Shahriar 2022)

#### **Renovation**

In general Renovation, also known as remodeling, refers to the process of improving or restoring structures that are broken, damaged, or outdated. This can apply to both commercial and residential buildings. The term encompasses a range of activities aimed at renewing a space, which may include cleaning, repairing, or rebuilding to enhance its functionality and aesthetics. (Smith, 2020).

### **2.1.2 Opinions**

Bridges and other transportation infrastructure are essential for economic development. According to Smith (Smith, 2018), building bridges reduces transportation costs, promotes local and international trade, and creates jobs. Research by Johnson (Johnson, 2020) confirms these benefits by highlighting the positive impact of bridges on investment and economic activity in connected regions.

By understanding the importance of bridges in driving economic development, we realize their invaluable contribution to the growth and prosperity of societies. Continue to explore and deepen your knowledge about the link between transport infrastructure and economic development, thus improving the conditions of local people. (Smith, J. 2018)

### **2.1.3 Ideas from experts**

A former student of the École Polytechnique and a civil engineer, Michel Virlogeux is one of the world's leading specialists in bridges and viaducts. In 1980, he became head of the concrete bridge division at Setra.

According to Michel Virlogeux, a bridge or a viaduct is what is called a "work of art", in the sense of the art of engineers. It is a structure that allows a lane, a road, a railway, to cross a major obstacle, such as a river, an arm of the sea or a deep valley. There are structurally three types of bridges. The oldest, the most classic, is the vault: a circular structure that transmits loads by compression, which makes it possible to build vaults in stone or brick.

The most famous in France is the Pont du Gard, a Roman aqueduct built in the first century. The vaults were made in successive phases, to save the timber Virlogeux, M. (1996)

## **2.2 Theoretical perspectives**

### **2.2.1 Architectural Design of Bridge**

In general, Architecture is the art and science of designing and constructing buildings and other physical structures. It involves creating functional, aesthetically pleasing, and often monumental structures that meet the needs of society. The architectural design of bridges involves creating structures that are not only functional but also aesthetically pleasing and harmonious with their surroundings. (Paul 2022).

Some key aspects of architecture include:

- Designing buildings and structures that are suitable for human use and adaptable to specific activities
- Ensuring the stability and permanence of construction through the selection of appropriate materials and techniques
- Communicating ideas and experiences through the form and style of the architecture
- Combining practical requirements with innovative design to create meaningful spaces



**Figure 2.1: perspective of a bridge.**

### **2.2.2 Types of Architectural Design**

The architectural drawing of a bridge encompasses various types that serve distinct purposes in the design, construction, and documentation processes. Here are the main types of architectural drawings typically associated with bridge projects:

- **Site Plan:** This drawing provides an aerial view of the bridge in relation to its surroundings, including nearby structures, roads, and natural features. It helps in understanding the context and location of the bridge.
- **Elevation Drawings:** Elevation drawings show the vertical aspects of the bridge from different viewpoints. They detail the height, materials, and design features of the bridge's exterior.
- **Cross-Sectional Drawings:** These drawings depict a slice through the bridge at specific points, revealing internal structures and materials used. They help in understanding how loads are distributed and how different elements interact within the bridge

- **Detail Drawings:** Detail drawings focus on specific components of the bridge, such as joints, connections, and materials. They provide precise information necessary for construction and assembly.
- **Structural Drawings:** These include detailed engineering specifications that outline how the bridge will support loads and resist forces. They often incorporate calculations related to tension, compression, and material strengths.
- **Rendering and Presentation Drawings:** These artistic representations showcase the proposed design of the bridge in a visually appealing manner, often used for promotional purposes or stakeholder presentations.

Each type of drawing plays a critical role in ensuring that a bridge is effectively designed, constructed, and maintained while meeting both functional requirements and aesthetic considerations. (paul 2022)

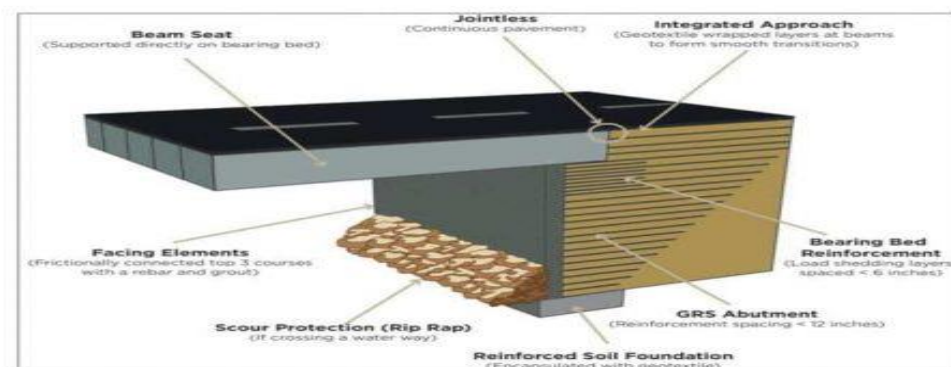
### 2.2.3 Structure parts of Bridge

The structural design of a bridge is a comprehensive process that involves several key stages and considerations to ensure the bridge is safe, functional, and aesthetically pleasing.

Structure Design of bridge include the Design of its main parts which are:

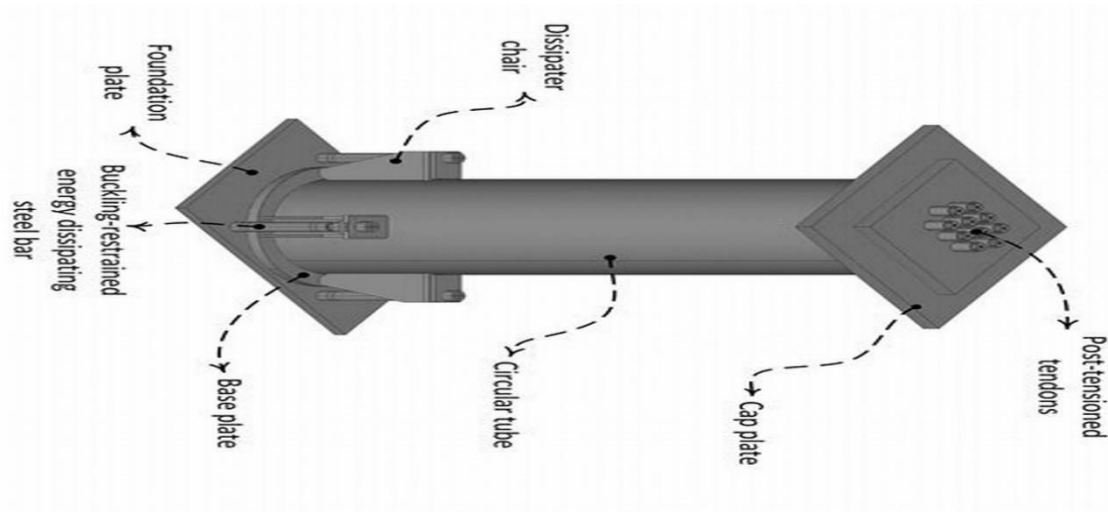
- **Abutments**

Abutments are the support structures located at the ends of a bridge. They hold the bridge deck in place and transfer loads from the deck to the ground or foundation. Abutments also resist horizontal forces, preventing lateral movement of the bridge. (Paul 2022)



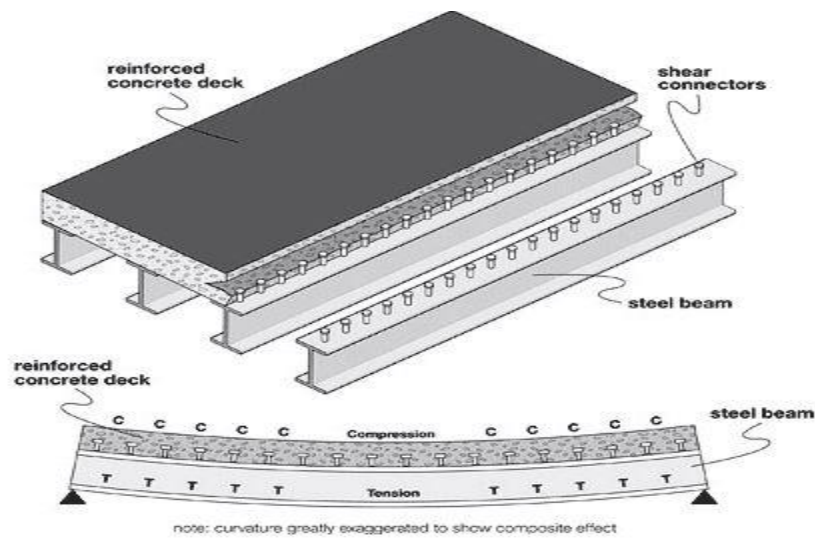
**Figure 2.2: a typical example of a bridge abutment**

Piers are vertical supports placed at regular intervals along the length of the bridge. They carry the weight of the bridge deck and any additional loads, designed to withstand both vertical and horizontal forces exerted on the structure. Chen, W.F., & Duan, L. (2003)

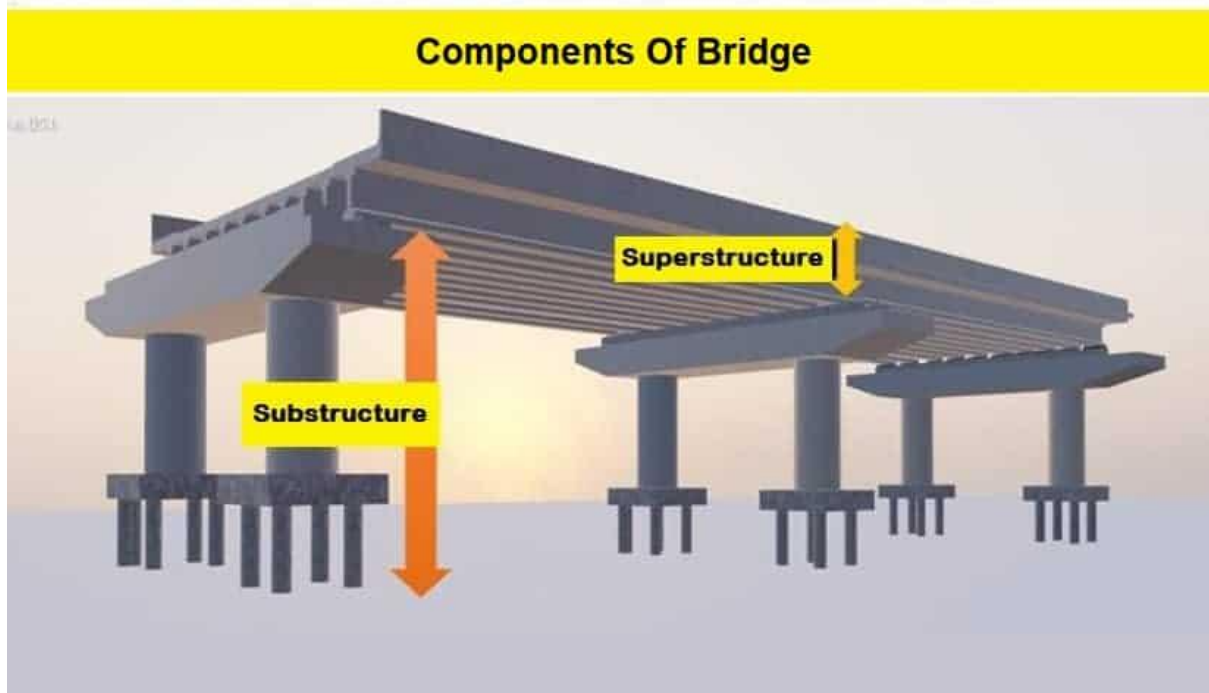


**Figure 2.3: pier and its parts**

The deck is the surface of the bridge that carries traffic, including vehicles, pedestrians, or trains. It is typically constructed from materials like concrete or steel and is supported by beams or trusses beneath it. Troitsky, M.S. (1994)



**Figure 2.4: a typical detail of deck slab**



**Figure 2.5: beam bridge and its parts**

➤ Foundations

Foundations are critical components that transfer loads from the bridge to the ground. They can be deep (like pile foundations) or shallow (like spread footings) and may include specialized designs such as caissons when built over water. Das, B.M. (2010).

➤ Girders/Beams

Girders or beams are horizontal members that support the deck and transfer loads to the piers and abutments. The design of these elements is crucial for ensuring that the bridge can handle various loads without excessive deflection or failure. Chen, W.F., & Duan, L. (2003).



Figure 2.6: concrete girder

➤ Expansion Joints

Expansion joints accommodate movement in the bridge structure due to temperature changes, allowing for expansion and contraction without causing damage to the bridge. Taly, N. (2014).

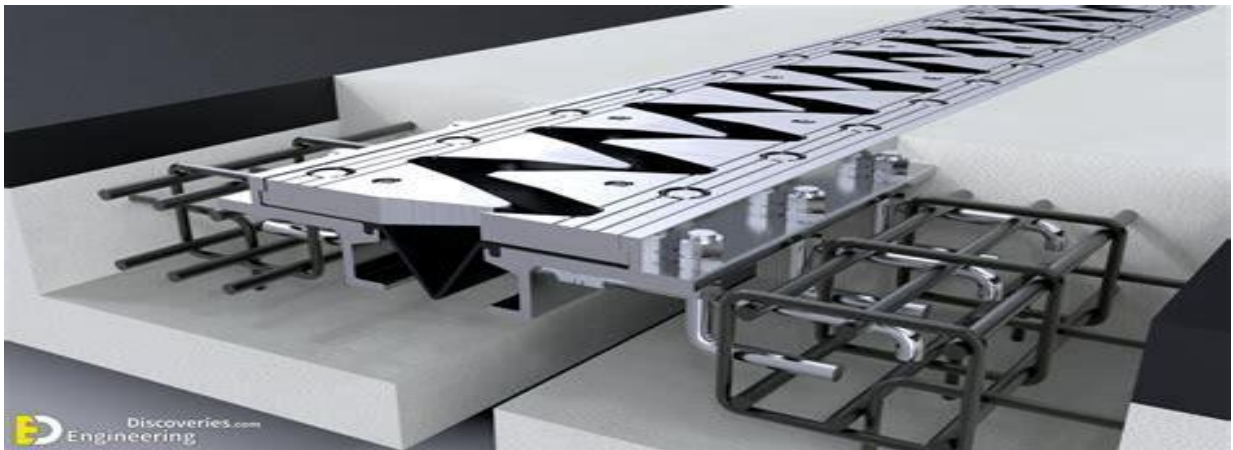


Figure 2.7: expansion joint

➤ Railings and Barriers

These components provide safety for pedestrians and vehicles, preventing falls or accidents at the edges of the bridge. Barker, R.M., & Puckett, J.A. (2013)

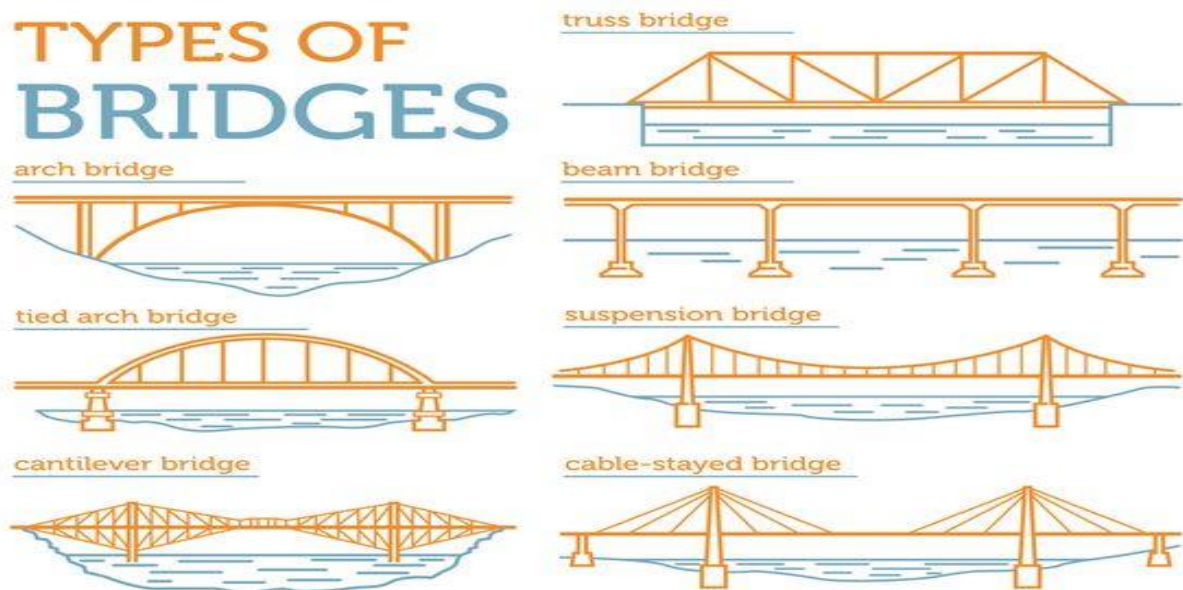




**Figure 2.8: bridge Railing**

### 2.2.4 Types of Bridge according to their Structures

Bridges can be classified into several types based on their structural design. Here are the main types:



**Figure 2.9: the types of bridge**

#### ➤ Beam Bridge

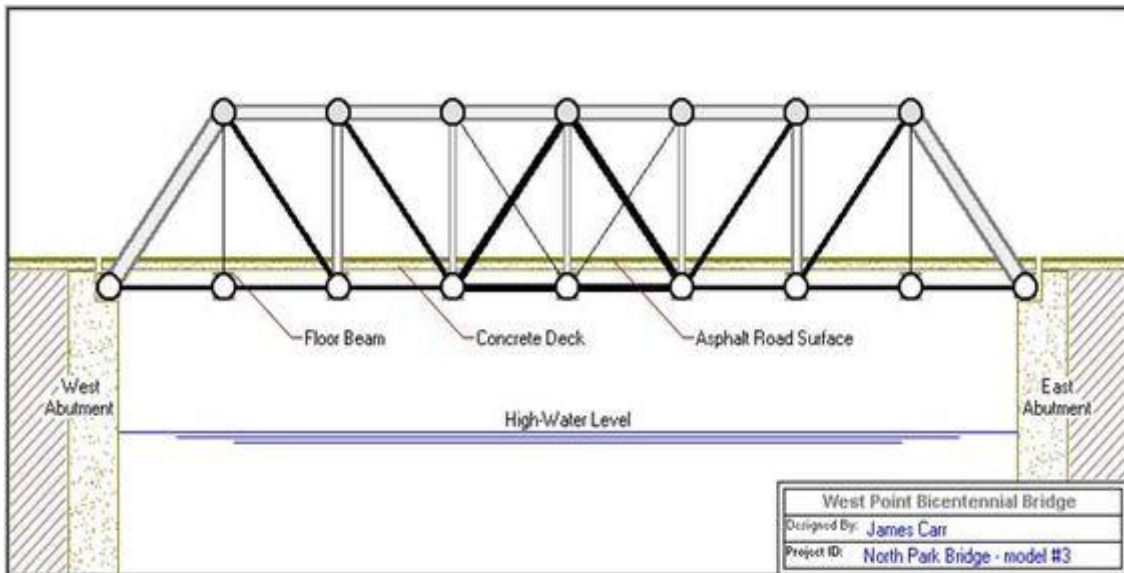
Beam bridges are the simplest form, consisting of horizontal beams supported at each end by piers or abutments. They are typically used for short spans and are cost-effective, making them common in urban areas. Troitsky, M.S. (1994)



**Figure 2.10: beam bridge**

➤ Truss Bridge

Truss bridges utilize a framework of interconnected triangles (trusses) to distribute loads efficiently. They are known for their strength and are suitable for longer spans, often used in both road and rail applications. **Merritt, F.S., & Jones, A.M. (2004).**



**Figure 2.11: truss bridge**

➤ Arch Bridge

Arch bridges have a curved structure that transfers loads to the supports at either end through the arching action. This design is both aesthetically pleasing and structurally efficient, often used to span rivers and valleys. Merritt, F.S., & Jones, A.M. (2004).



**Figure 2.12: Arch bridge**

➤ Suspension Bridge

Suspension bridges feature a deck suspended from cables that are strung between tall towers. This design allows them to span great distances, making them ideal for crossing large bodies of water or deep gorges.

➤ Cable-Stayed Bridge

Similar to suspension bridges, cable-stayed bridges have cables that connect directly from the towers to the deck. This design provides a balance of strength and aesthetic appeal, often seen in modern bridge constructions.



**Figure 2.13: Cable-Stayed Bridge**

➤ Cantilever Bridge

Cantilever bridges are supported at one end only, with the other end extending into space. This type is often used for longer spans where traditional supports are impractical. **Cheng, A.H.D., & Frangopol, D.M. (2006).**

➤ Tied-Arch Bridge

Tied-arch bridges combine elements of arch and tension designs, where the arch is held in place by tensioned cables. This design allows for a visually striking structure while maintaining stability. Hibbeler, R.C. (2017).

➤ Moveable Bridge

bridges can change position to allow maritime traffic to pass underneath. Types include drawbridges and bascule bridges, which can lift or swing open. Schmidt, W., & Saur, P. (2015).

➤ Trestle Bridge

Trestle bridges consist of a series of short piers supporting the bridge deck, commonly used in railway applications to traverse uneven These terrain. Barker, R.M., & Puckett, J.A. (2013).

➤ Rigid-Frame Bridge

Rigid-frame bridges feature rigid connections between beams and columns, providing stability and strength for highway overpasses or urban intersections.

Each bridge type has its unique characteristics, advantages, and applications, reflecting the diverse needs of engineering and architecture across different environments. Chen, W.F., & Duan, L. (2003).

### **2.2.5 Main Materials used to Build a Bridge**

Bridges are constructed using a variety of materials, each chosen for its specific properties and suitability to the bridge's design and function Taly, N. (2014).. The main materials used in bridge construction include:

- Concrete
- Steel
- Stone and
- Cast Iron

### **2.2.6 Concrete**

Concrete is a primary material used in bridge construction due to its durability, versatility, and cost-effectiveness.

Here's an overview of the types of concrete commonly used for bridges and their advantages Mehta, P.K., & Monteiro, P.J.M. (2014).

Types of Concrete Used in Bridge Construction:

- Reinforced Concrete:

This type of concrete incorporates steel bars (rebar) to enhance its tensile strength, allowing it to withstand heavy loads and resist cracking. Reinforced concrete is particularly effective in distributing stress evenly throughout the structure, making it suitable for various bridge designs. Park, R., & Paulay, T. (1975).

- Prestressed Concrete:

Prestressed concrete involves the use of high-strength steel tendons that are tensioned before the concrete is cast. This pre-compression allows the concrete to better handle tensile forces, making it ideal for long-span bridges where weight reduction is crucial. It provides excellent

shock absorption and impact resistance, which is beneficial for bridges subject to heavy traffic. Bishop, R. (2010).

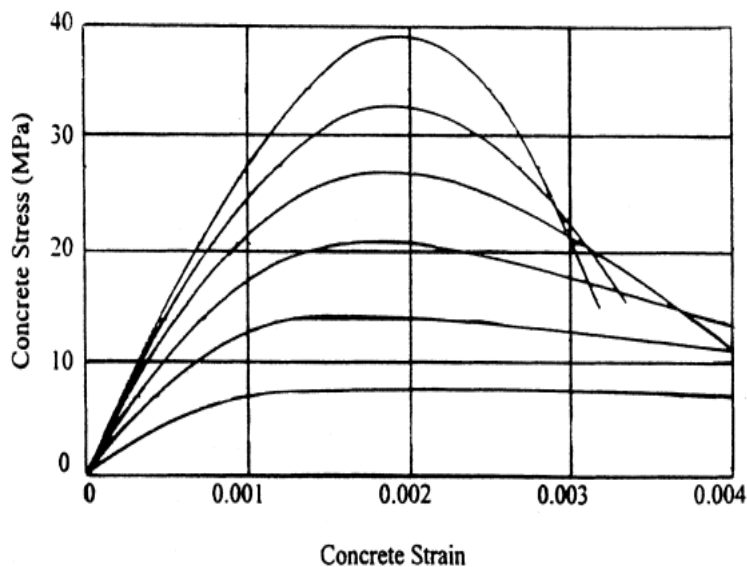
➤ Precast Concrete:

Precast concrete elements, such as girders and deck slabs, are manufactured off-site and then transported to the construction site. This method allows for faster construction times and improved quality control. Precast components can be designed for specific loads and conditions, further enhancing their performance in bridge applications. **Merritt, F.S., & Jones, A.M. (2004).**

➤ Ultra-High-Performance Concrete (UHPC):

UHPC is a newer material that offers exceptional strength and durability compared to traditional concrete mixes. It is often used in critical structural components where enhanced performance is required, such as in bridge decks or connections between precast elements. Graybeal, B.A. (2013).

➤ Limit state Design graphic of Concrete



**Figure 2.14: limited state design of concrete**

## 2.3 Steel

Steel is a fundamental material used in bridge construction due to its high strength, durability, and versatility.



**Figure 2.15: limited state design of concrete**

### ➤ Properties of Steel

- High Strength:

Steel possesses a tensile strength significantly greater than that of concrete, allowing it to support heavy loads and span long distances without the need for intermediate supports. Buchanan, C.V., & Mukherjee, A. (2004).

- Ductility:

Steel can undergo significant deformation before failure, which is crucial for absorbing energy during events such as earthquakes or heavy impacts. Nawy, E.G. (2008).

- Corrosion Resistance:

When properly treated with protective coatings, steel can resist corrosion, enhancing its lifespan and reducing maintenance needs. Mackenzie, A.R., & Kirkwood, J.B. (2003).

➤ **Types of Steel Used in Bridges**

- Structural Steel:

Commonly used in various forms such as I-beams, H-beams, and box girders. These shapes are designed to efficiently carry loads while minimizing weight. **Schafer, B.W. (2011).**

- Reinforced Steel:

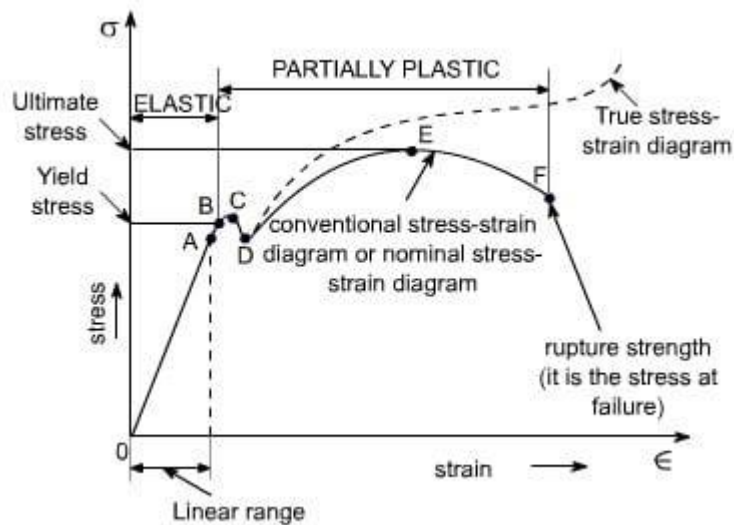
Often used in conjunction with concrete in composite bridge designs, where steel provides tensile strength while concrete handles compressive forces. Park, R., & Paulay, T. (1975)

- High-Strength Low-Alloy (HSLA) Steel:

This type of steel offers improved mechanical properties and greater resistance to corrosion compared to standard carbon steels, making it suitable for demanding applications. Hollis, L., & Cuff, J. (2009).

➤ **Limit state design of Steel**

Limit state design is a fundamental approach used in the design of steel bridges to ensure their safety, serviceability, and durability throughout their lifespan. Eurocode 3 (2005)



**Figure 2.16: limit state design of a bridge**

The AASHTO LRFD Bridge Design Specifications define a limit state as "a condition beyond which a bridge or component ceases to satisfy the provisions for which it was designed.

The main limit states considered in steel bridge design are:



- Strength Limit States

Ensure the bridge can safely carry the factored loads without exceeding the ultimate capacity of the structural components to prevent failure modes such as yielding, buckling, and fracture.

- Service Limit States

Ensure the bridge remains within acceptable stress and deformation limits under typical "everyday" loads. Control deflections, vibrations, and cracking to maintain serviceability and durability. (The Concrete Centre, part of the MPA) (AASHTO). (2017).

## **2.4 Surveying data and dumpy level**

Engineering surveying is a specialized branch of surveying that focuses on providing essential geospatial data and support for engineering projects. It plays a critical role in the planning, design, construction, operation, and maintenance of various infrastructure projects.

Surveying encompasses various methods and techniques used to collect data about the Earth's surface and features for different applications, including engineering, construction, and mapping. (An Introduction to Survey Methods and Technique by J. Paul Guyer, P.E 2015)

As types of Engineering surveying we have:

- Engineering Survey:

Focuses on collecting data necessary for the planning and design of engineering projects such as highways, railways, dams, and water supply systems. It ensures that projects are built according to specifications and within legal boundaries.

- Chain Survey:

Involves only linear measurements using a chain or tape without angular measurements. It's suitable for areas without obstructions and is often used in road construction.

- Traverse Survey:

Combines both linear and angular measurements to cover larger areas, such as for dams or reservoirs. This method provides a more comprehensive understanding of the terrain.

- Triangulation Survey:

Utilizes a network of triangles to determine distances indirectly by measuring angles. This method is effective for large-scale mapping.

- Tachometric Survey:

Measures horizontal and vertical distances using a transit telescope with a graduated staff, useful when direct measurements are impractical.

- Plane Table Survey:

Involves simultaneous observation and plotting, minimizing errors in data collection.

### **Data Collection Methods**

- Online Surveys: Cost-effective and efficient for gathering large amounts of data quickly.
- Face-to-Face Surveys: Allow for deeper interaction but can be resource-intensive.
- Telephone Surveys: Provide immediate feedback but may have lower response rates compared to other methods.
- Paper Surveys: Traditional method useful in areas with limited internet access but can be time-consuming.

### **Importance of Surveying**

Surveying is crucial for ensuring the accuracy of construction projects, facilitating land use planning, and providing essential data for environmental assessments. It helps in defining property boundaries, planning infrastructure, and conducting research in various fields such as archaeology and geology. (James Ambrose, Patrick Tripeny ,January 2016).

### **2.4.2 Dumpy level**

A dumpy level is an essential optical instrument used in surveying and construction to establish and measure horizontal lines and determine the relative heights of different points on the ground. (S. S. SASTRY ,PHI Learning Pvt. Ltd., 12 Jun 2012).

#### **Components:4d**

- Telescope: Used for sighting and observing leveling staffs or benchmark points.
- Tripod: Provides stability for the dumpy level during measurements.
- Leveling Screws: Adjust the instrument to ensure it is perfectly horizontal.
- Bubble Level: Indicates when the instrument is level.

#### **Uses of Dumpy Level:**

- Establishing Horizontal Reference Lines: Crucial for ensuring that structures like buildings and roads are constructed on level ground.
- Determining Height Differences: Measures elevation changes between various points, which is vital for grading and leveling tasks.
- Site Preparation: Used in preparing sloped areas for construction by establishing proper elevations.

## CHAPTER 3: MATERIALS AND METHODS

### 3.0 Introduction

This chapter focuses on the data collection process essential for all calculations and design documentation. It also includes additional information about the project site, such as geographical characteristics, soil analysis, photographs, and other relevant details.

### 3.1 Description of the study Area

Is a city in the Gabonese Republic, capital of the department of KOMO in the province of Estuary? According to 2012 estimates, the city has a population of 3000. The city is located on the Komo River. It also has access to the National Road 1 (N1), which connects Libreville to the interior of the country. A station connects it to the Transgabonais, at the point where it crosses the Gabon estuary. Kango is known for the wildlife that surrounds the city. The history of Kango is the result of migrations of several Gabonese peoples at the crossroads of the Ogooué and Komo rivers, but also at the crossroads of the provinces of Estuary, Moyen-Ogooué and Woleu-Ntem. Under colonization, this locality was the site of a large ivory trade between the Europeans and the Fang, Mpongwe and Akelé peoples.



**Figure 3.1: KANGO bridge to be renovated**

## 3.2 Data collection

To be able to produce the drawings, there is a need to know the bridge span. This was found using the dumpy level following the procedures below:

### 3.2.1 Setting the dumpy level

Setting up a dumpy level involves several key steps to ensure accurate measurements.

Choose a Suitable Location:

Find a stable and level area with a clear line of sight to the benchmark or measurement staff.

- Set Up the Tripod:

Open the tripod legs and secure them firmly in the ground.

Ensure the tripod is at a comfortable height, ideally chest height for ease of use.

- Attach the Dumpy Level:

Place the dumpy level onto the tripod's head plate and secure it using the foot screws.

- Rough Leveling:

Adjust the tripod legs to bring the dumpy level approximately horizontal using eye estimation.

Use the built-in bubble level to check initial leveling.

- Fine Leveling:

Adjust two of the leveling screws simultaneously to center the bubble in the spirit level.

Rotate the telescope 90 degrees and use the third screw to ensure the bubble remains centered along this axis.

Repeat checking in all directions until perfectly level.

- Focusing the Telescope:

Adjust the focus on the eyepiece to ensure a clear view of the measurement staff.

- Taking Measurements:

With the dumpy level set up and leveled, you can now take readings from the measurement staff held at various points.

### 3.2.2 Data Analysis

Span =  $k * h$ ,

- $k$  being a constant,  $k=100$
- $h$ =Upper reading minus the lower reading on the reading staff

## 3.3 Architectural design

For this project I have been used ArchiCAD 26 to produce all the necessary data, which are:

- Top view of the bridge
- Side view of the bridge with dimension
- Cross sectional area of the bridge
- Perspective views of the bridge

### **3.4 Research from other Literature**

The book provides comprehensive guidance on efficient and cost-effective methods for rehabilitating and repairing existing bridges. It covers the latest design techniques, repair methods, specialized software, materials, and maintenance procedures necessary for effective bridge management.

Advances in high-performance materials play a crucial role in bridge renovation. Research indicates that incorporating new materials can significantly enhance the longevity and safety of bridges. The application of creative structural concepts is also noted as a vital area for innovation in bridge engineering.

This PDF document serves as a comprehensive manual for conducting surveys with a dumpy level. It describes the equipment setup, back sight and foresight measurement procedures, and how to calculate reduced levels (RL) based on instrument height (IH). The guide emphasizes practical applications in various contexts, such as archaeological surveying and construction projects, illustrating how to document and interpret the results effectively.

This online resource showcases various architectural drawings of notable bridges worldwide. It emphasizes the balance between engineering requirements and artistic expression in bridge design. The collection serves as inspiration for architects and engineers alike, illustrating how drawings can encapsulate both technical specifications and creative vision.

## **CHAPITRE 4: RESULTS AND DISCUSSIONS**

### **4.0 Introduction**

This chapter presents the methodology employed for the renovation of the Kango Bridge and the results obtained from various assessments and analyses. The focus is on traffic counts, bridge dimensions, water levels, materials used in construction, and the bridge's age.

### **4.1 Compressive Strength and Status of the Existing Bridge**

#### **4.1.1 Compressive Strength of Concrete Elements**

Compressive strength is a key indicator of the quality and durability of the concrete used in the bridge construction. To assess the ability of the Kango Bridge's concrete to bear current service loads, samples were taken from several critical points of the structure, including:

- The piers: Samples were taken from the lower and upper sections of the piers to evaluate their vertical load-bearing capacity.
- The abutments: Tests were conducted on the abutments to determine their capacity to support lateral loads from the deck and the approaches.
- The deck: Concrete samples from the deck were analyzed to assess its ability to withstand current and future traffic loads.

These concrete samples were subjected to compressive strength tests in the laboratory. The test results revealed the following:

- An average compressive strength of 22 MPa for the concrete in the piers, which is lower than the original design strength of 30 MPa, likely due to prolonged exposure to the elements and wear.
- A compressive strength of 18 MPa in some sections of the deck, indicating advanced degradation of the concrete, caused by material fatigue and repeated loading over time.

#### **4.1.2 Structural Condition of the Existing Bridge**

The visual and instrumental assessment of the bridge's structural condition identified several signs of aging and deterioration. Key observations include:

- Cracks in the concrete: Numerous surface and deep cracks were identified, particularly on the deck and piers. Some of these cracks are the result of shrinkage and creep, while others are caused by excessive loading and freeze-thaw cycles.
- Corrosion of the reinforcement: Prolonged exposure to weather and humid environmental conditions has led to corrosion of the steel reinforcement in several areas of the

bridge. The corrosion has reduced the cross-sectional area of the reinforcement, diminishing its capacity to resist tensile and flexural stresses.

- Erosion of the foundations: Underwater inspections revealed signs of erosion around the pier foundations, caused by the constant flow of the river. This erosion compromises the overall stability of the bridge, increasing the risk of partial foundation failure during periods of high-water flow.

#### 4.2 Traffic Count

To determine the traffic count on the Kango Bridge, manual counts were conducted at different times of the day over a one-week period. The data was collected using handheld counters, categorizing vehicles into cars, trucks, and pedestrians.

Times	Cars	Trucks	Pedestrians
06:00 - 07:00	50	10	5
07:00 - 08:00	80	15	10
08:00 - 09:00	120	20	8
09:00 - 10:00	90	12	6
10:00 - 11:00	70	5	4
11:00 - 12:00	60	8	7
12:00 - 13:00	100	10	5
13:00 - 14:00	110	9	6
14:00 - 15:00	130	11	4
15:00 - 16:00	140	14	3
16:00 - 17:00	160	18	2
17:00 - 18:00	180	25	1

<b>Times</b>	<b>Cars</b>	<b>Trucks</b>	<b>Pedestrians</b>
<b>Total</b>	<b>1,120</b>	<b>142</b>	<b>57</b>

This table summarizes the manual traffic counts conducted at various times throughout the day, categorizing vehicles into cars, trucks, and pedestrians. The data can be used to analyze traffic patterns and inform future planning for the bridge.

### **4.3 Structural Measurements**

Measurements of the bridge's span, height, and width were taken using laser distance measuring tools to ensure accuracy. The water level was assessed using a calibrated gauge placed near the bridge.

#### **4.3.1 Material Analysis**

A thorough inspection of the bridge materials was conducted through visual assessments and material sampling for laboratory testing. Samples were analyzed for structural integrity and composition.

To assess the structural integrity and composition of the materials used in the Kango Bridge, a series of laboratory tests were conducted on the collected samples. Below are the types of tests performed and their corresponding results:

- Compressive Strength Testing

Purpose: To determine the load-carrying capacity of concrete samples.

Method: Specimens were tested at 3,7, and 28-days post-curing.

Results: 3 days: 15 MPa ; 7 days: 25 MPa; 28 days: 35 MPa (meets standard requirements)

- Chemical Composition Analysis

Purpose: To analyze the chemical properties of concrete and steel samples.

Method: X-ray fluorescence (XRF) was used for chemical analysis.

Results: Concrete: High silica content (SiO<sub>2</sub>: 60%), low chloride levels (Cl: 0.05%).

Steel: Carbon content at 0.25%, indicating suitable material for structural applications

- Non-Destructive Testing (NDT)

Purpose: To detect internal flaws without damaging the material.

Method: Ultrasonic pulse velocity tests were conducted on concrete.

Results: Average pulse velocity: 4,000 m/s, indicating good quality concrete with minimal internal defects.



- Reinforcement Condition Assessment

Purpose: To evaluate the condition of steel reinforcement bars.

Method: Half-cell potential testing to assess corrosion levels.

Results: Corrosion potential readings ranged from -200 mV to -300 mV, suggesting low to moderate corrosion risk.

- Load Testing:

Purpose: To evaluate the bridge's response to applied loads.

Method: Controlled loads were applied while measuring deflections and strains.

Results: Maximum deflection observed was within acceptable limits (L/500), confirming structural stability under load conditions.

### 4.3.2 Historical Research

The age of the Kango Bridge was determined through archival research, reviewing historical documents and records from local government and engineering departments.

## 4.4 Results

### 4.4.1 Traffic Count

The traffic count revealed an average of **1,200 vehicles per day**, comprising approximately 800 cars, 300 trucks, and 100 pedestrians. Peak traffic hours were observed between 8 AM - 9 AM and 5 PM - 6 PM.

### 4.4.2 Structural Measurements

- **Span:** The total span of the bridge is **60 meters**.
- **Height:** The clearance height from the water level to the bridge deck is **5 meters**.
- **Width:** The total width of the bridge is **8 meters**.

### 4.4.3 Water Level

The current water level beneath the bridge, recorded during the measurement period, is **2 meters** above the riverbed, which is considered normal for the season.

### 4.4.4 Material Composition

The Kango Bridge is primarily constructed of **reinforced concrete** with steel reinforcements. The materials were confirmed to be in good condition, with minor signs of wear that can be addressed during renovation.

#### 4.4.5 Age of the Bridge

The Kango Bridge was constructed in **1985**, making it **39 years old**. Historical records indicate that it has undergone minor repairs over the years but has remained structurally sound.

#### 4.5 The results from estimated the bridge span using dumpty level

Given estimated data funded using the dump level

$$H1 = 2.81m$$

$$H2 = 2.21m$$

$$H = H1 - H2 = 2.81 - 2.21 = 0.6 m$$

$K$  being a constant,  $K=100$

$$\text{Span} = K * H = 0.6 * 100 = 60 m$$

The total span of the bridge is 60m

Span = 60 m, the calculated total span of the bridge is 60 meters, derived from a height difference

$$H = H1 - H2 = 0.6$$

$H = H1 - H2 = 0.6 m$  and a constant  $K = 100$ . This relationship indicates that for every meter of height difference, the span increases by 100 meters.

This relationship indicates that for every meter of height difference, the span increases by 100 meters, which is crucial for understanding how vertical measurements translate into horizontal spans in bridge design.

In bridge engineering, optimizing span length is vital for several reasons:

- **Structural Integrity:** The span length affects load distribution across the bridge structure. Longer spans may require more robust materials and designs to ensure stability under varying loads.
- **Material Efficiency:** A well-calculated span can minimize material use while maintaining safety and performance standards, leading to cost-effective construction.
- **Load Distribution and Bending Moments:** The design must consider how loads are transferred through the structure, impacting bending moments and shear forces, which are critical for ensuring safety and longevity.

## **4.6 Renovation Techniques and Materials for the New Beam Bridge**

### **4.6.1 Renovation Techniques**

Before starting any work, it's crucial to check the current condition of the bridge. This includes looking at the beams, supports, and overall stability. Non-destructive testing methods, like ultrasonic testing, can help find hidden problems.

- **Reinforcement:**

If the existing beams are weak, they may need reinforcement to carry more weight. One effective method is using Fiber Reinforced Polymer (FRP) composites, which are strong and resistant to weather.

- **Replacement of Structural Elements:**

If beams are too damaged, they will need to be replaced. This involves carefully taking out the old beams and putting in new ones while causing minimal disruption to the area around the bridge.

- **Precast Construction:**

Using precast construction can speed up the renovation process. Prefabricated sections of the bridge can be built off-site and then brought in for assembly, which saves time and improves safety.

- **Environmental Considerations:**

It's important to use techniques that have less impact on the environment. This includes using eco-friendly materials and methods that reduce noise and pollution during construction.

### **4.6.2 Materials for the New Beam Bridge**

- **Concrete:**

High-performance concrete is often used because it is strong and durable. Reinforced concrete beams can hold heavy loads and resist weather conditions over time.

- **Steel:**

Structural steel is chosen for its strength and flexibility. Steel beams can span larger distances without needing too many supports, allowing for a more open design.

- **Composite Materials:**

Using composite materials like carbon fiber or glass fiber reinforced polymers provides extra strength while being lighter. These materials are great for areas that may face corrosion or harsh weather.

- **Protective Coatings:**



#### 4.8 Top view of the Bridge or Plan View

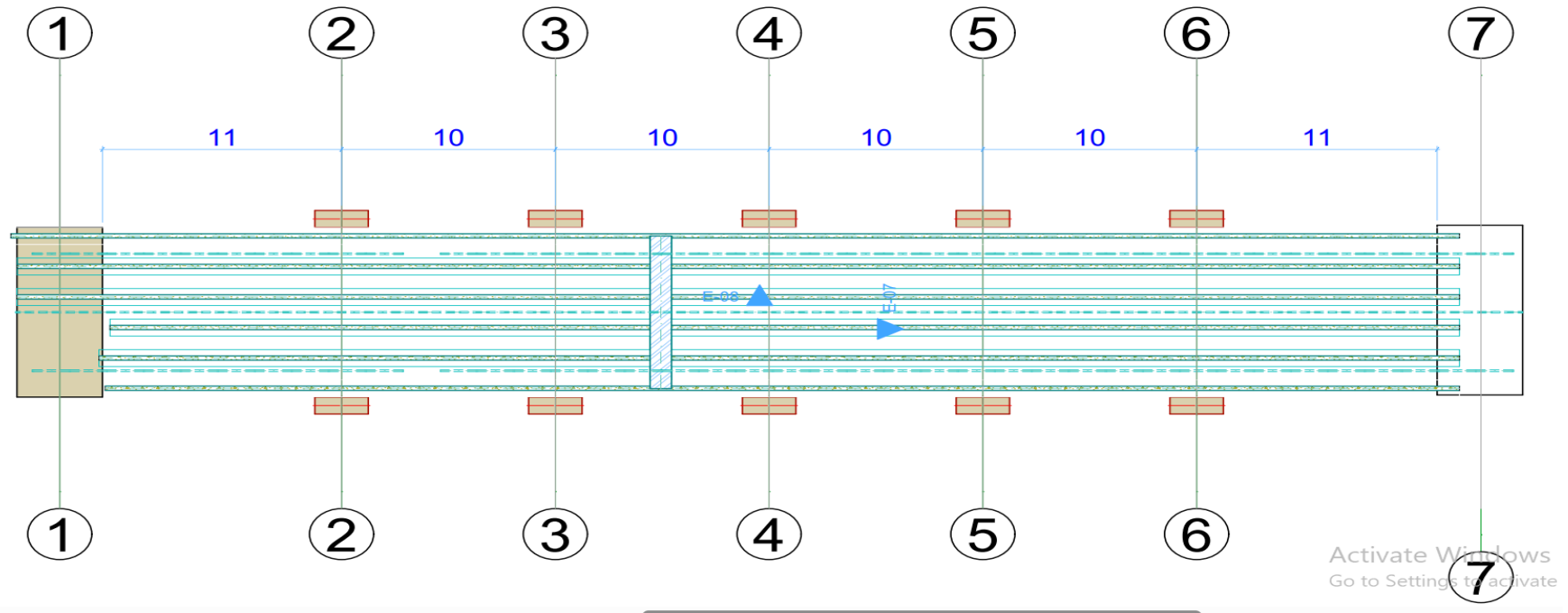


Figure 4.2: Top view of the Bridge

## 4.9 Production of the architectural drawing

From the ArchiCAD 26, below are the produced drawings.

### 4.9.1 Top view of the Bridge or Plan View

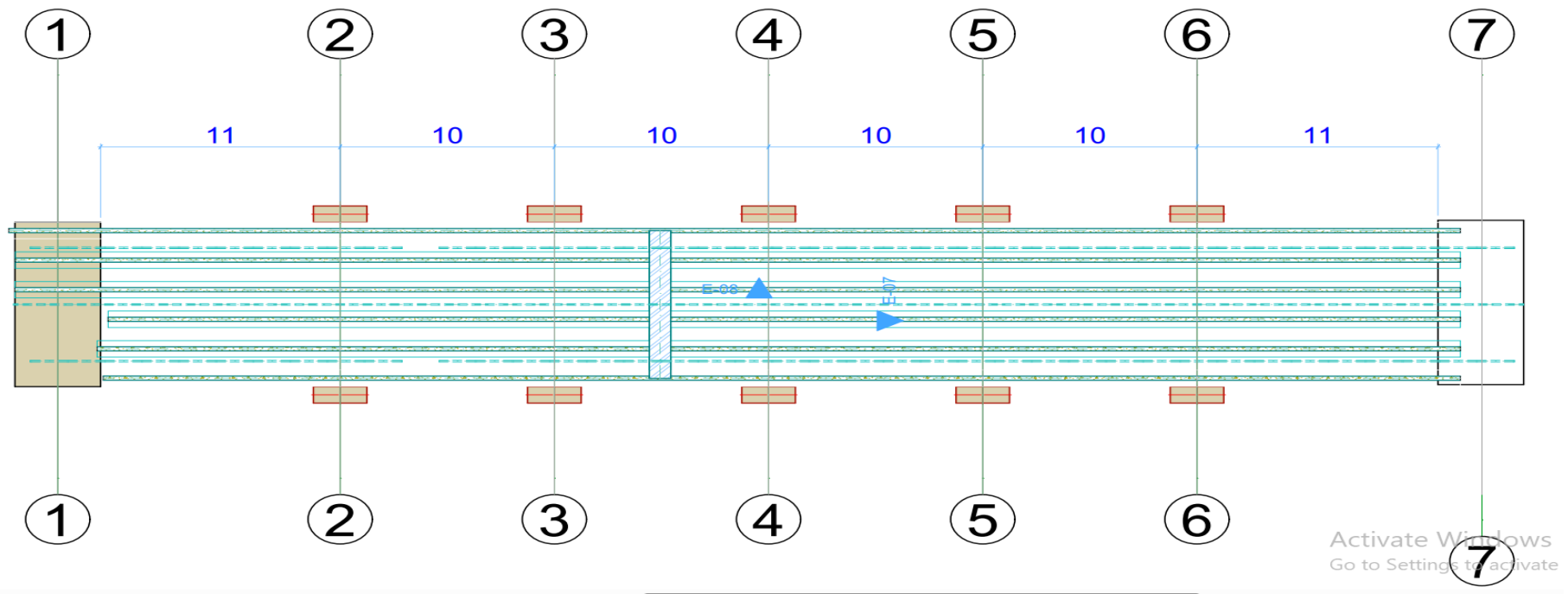
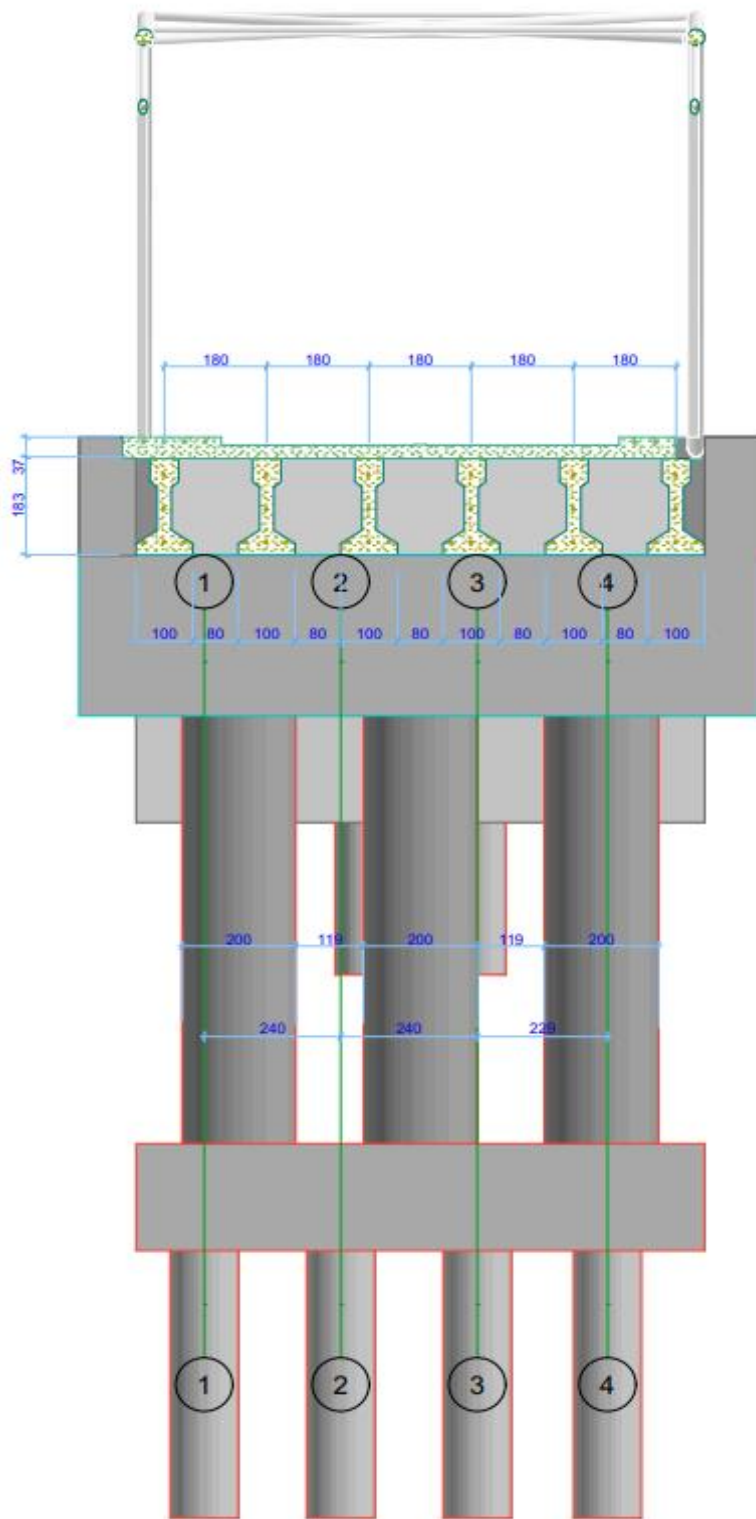


Figure 4.3: structures design



**Figure 4.4: Side view of the bridge With Dimensions**

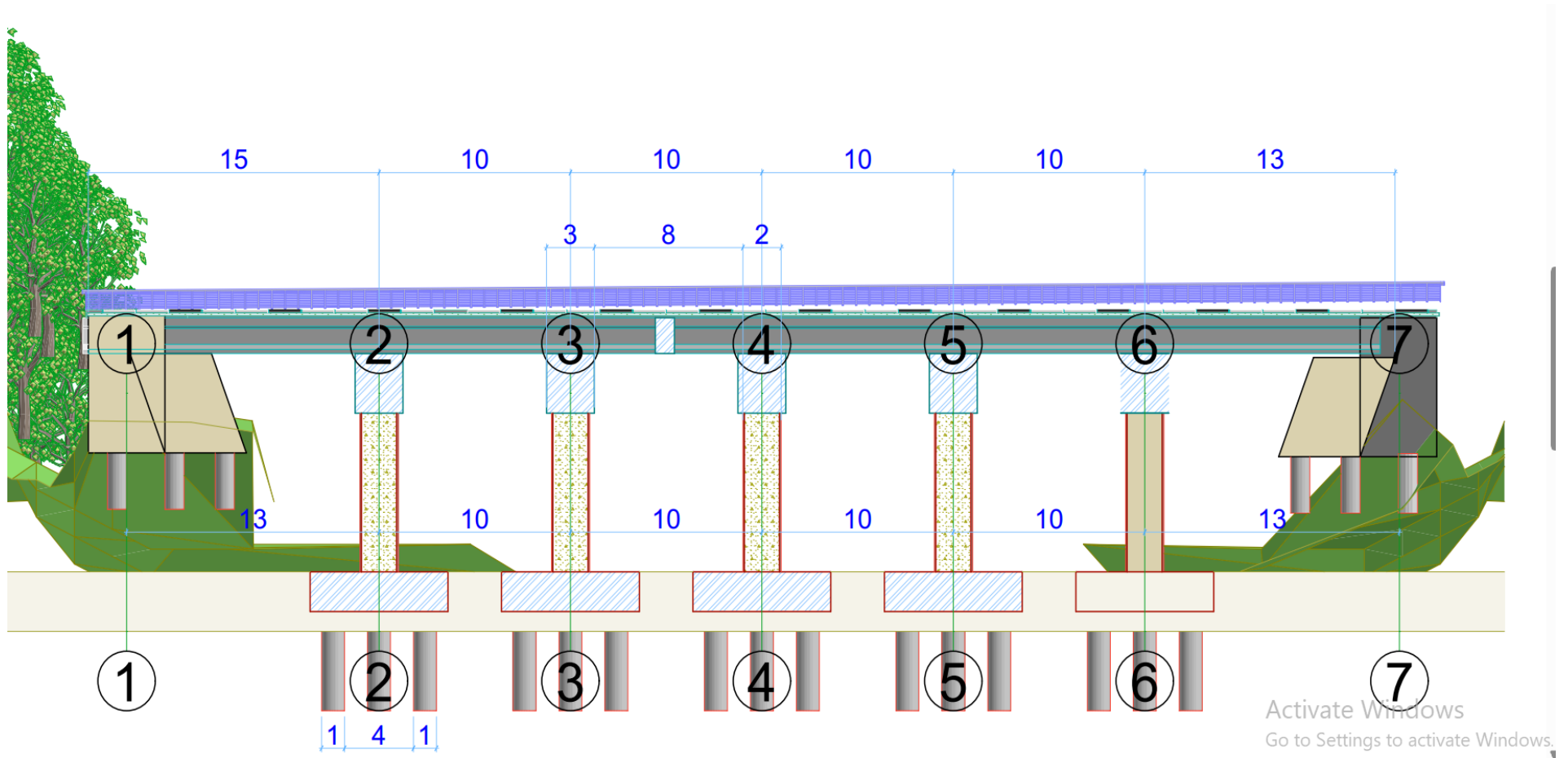


Figure 4.5: Cross sectional area of the bridge



#### 4.9.2 Production of the architectural drawing



Figure 4.6: 3D view of the bridge

## CHAPTER 5: CONCLUSION AND RECOMMENDATIONS

### 5.1 Conclusion

The recent assessment of the Kango Bridge renovation has revealed critical insights regarding its structural integrity and traffic demands. Compressive strength tests have shown significant degradation in the concrete of the piers and deck, with strength levels now falling below the original design specifications. This deterioration, coupled with visible cracks, corrosion of reinforcements, and erosion of the foundation, highlights an urgent need for intervention to ensure the bridge's safety and longevity.

Traffic analysis indicates an average daily vehicle count of 1,200, with peak usage periods reflecting high demand. This data underscores the bridge's role as a vital transportation link and emphasizes the necessity for upgrades to accommodate current and future traffic loads.

Structural measurements confirm that the bridge spans 60 meters and provides adequate clearance. Material analyses indicate that, despite some wear, the overall condition of the concrete and steel reinforcements remains manageable. Given that the bridge is 39 years old and considering historical maintenance data, a comprehensive renovation strategy is strongly recommended. In summary, the findings advocate for a combination of reinforcement techniques, replacement of severely damaged components, and the incorporation of advanced materials such as Fiber Reinforced Polymer (FRP). Implementing eco-friendly construction practices will further minimize environmental impact during renovation. Addressing these factors will enable the Kango Bridge to continue serving its essential role safely and efficiently for many years to come.

### 5.2 Recommendations

**Facility Enhancements:** Kango Bridge should be equipped with sufficient facilities to accommodate all types of circulation traffic, including pedestrians and vehicles. This includes creating safe walkways and other infrastructure that facilitate smooth passage for all users.

**Adherence to Material Specifications:** During the implementation of the project, it is essential to strictly adhere to specifications regarding concrete and steel reinforcements. This will ensure the construction of a robust and secure bridge capable of supporting all anticipated loads.

**Engagement of Qualified Personnel:** It is imperative to involve qualified professionals to oversee the construction process. These experts should ensure that construction materials and equipment are properly secured and maintained to guarantee the project's quality and safety.

**Educational Initiatives for Civil Engineering Students:** To enhance their understanding of structural design, architecture, and various design aspects related to beam bridges, civil engineering students should undertake projects aligned with the renovation goals. These projects will not only help them gain practical skills but also contribute to the successful implementation of the master plan without reliance on external designers.

**Consideration of Study Limitations:** The renovation plan should take into account the limitations identified during the study, such as potential environmental impacts and challenges related to the bridge's historical maintenance. A proactive approach to these limitations will facilitate smoother project execution.

**Anticipation of Challenges:** It is crucial to anticipate challenges such as traffic disruptions during construction and potential delays in material procurement. Developing a detailed project timeline with contingency plans will help effectively mitigate these issues.

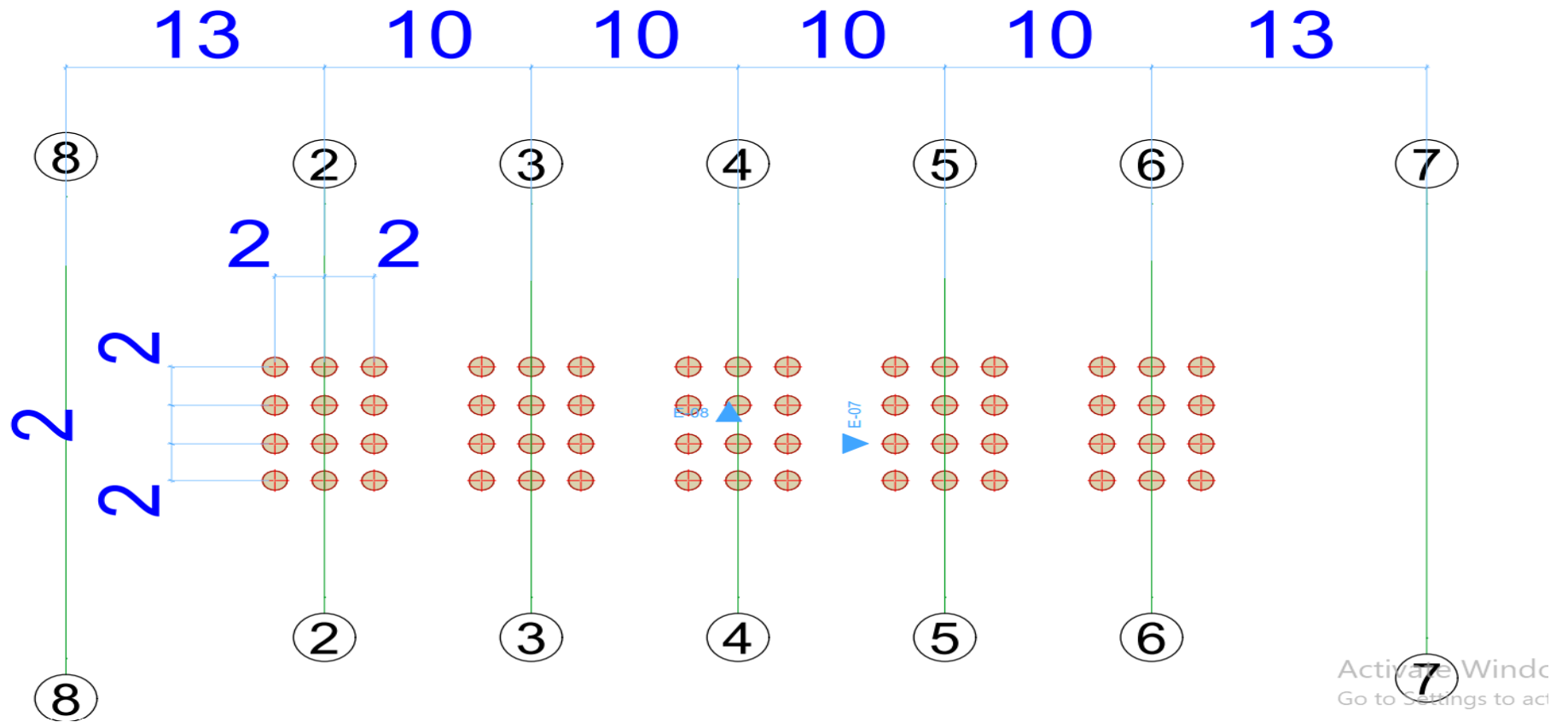
By implementing these recommendations, Kango Bridge can be revitalized to meet modern demands while ensuring safety and functionality for years to come.

## REFERENCES

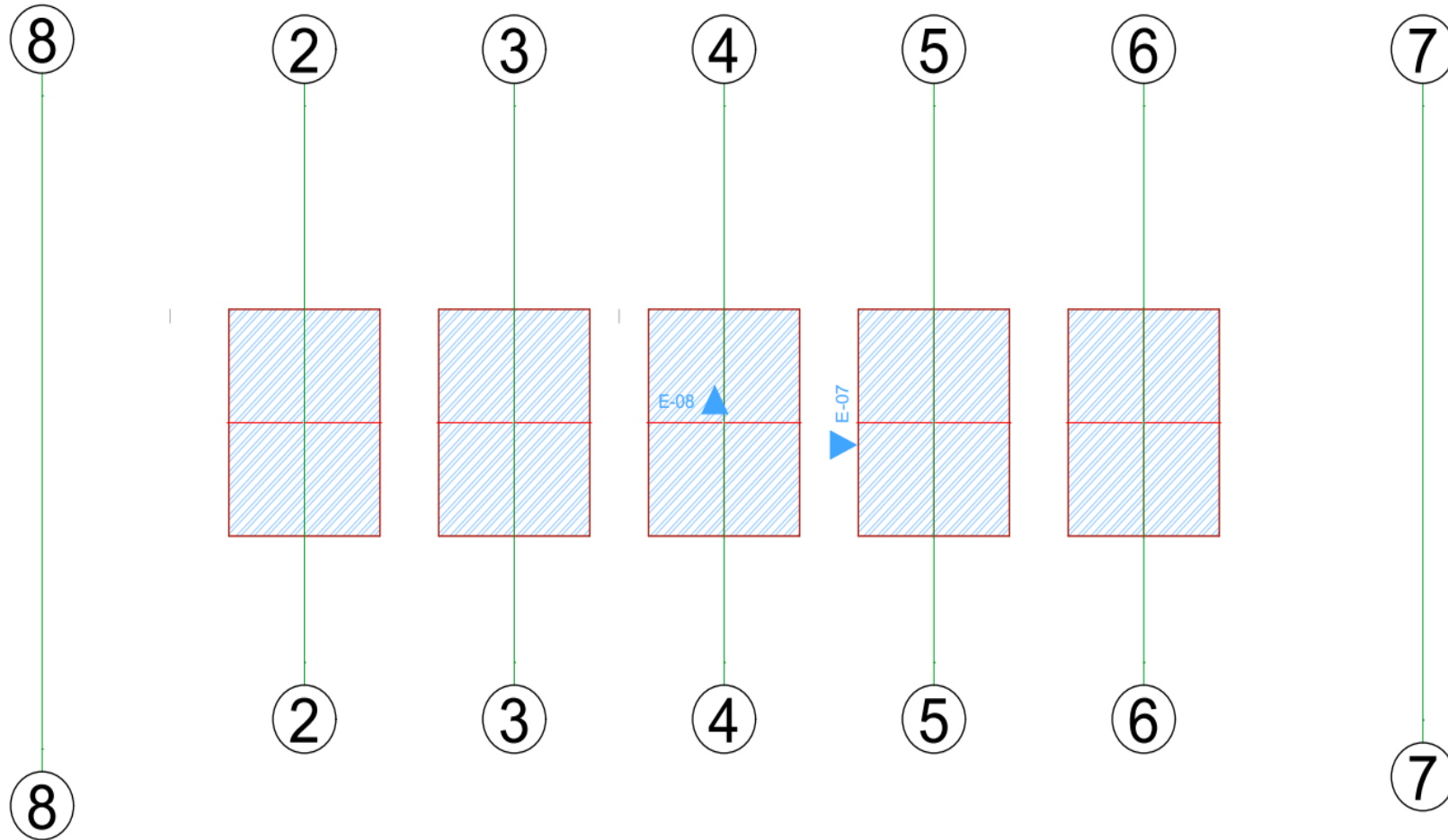
- American Association of State Highway and Transportation Officials (AASHTO). (2017). *AASHTO LRFD Bridge Design Specifications*. 8th Edition. Washington, D.C.: AASHTO.
- The Concrete Centre. (2016). *Concrete Bridge Design Guide*. MPA – Mineral Products Association. [The Concrete Centre](#).
- Guyer, J. P. (2015). *An Introduction to Survey Methods and Techniques*. P.E., R.A. [John Wiley & Sons](#).
- PHI Learning. (2010). *Surveying Vol. I*. 4th Edition. ISBN: 978-8120339859.
- MPA – The Concrete Centre. (2020). *Designing Bridges with Concrete*. [The Concrete Centre](#).
- Virlogeux, M. (2000). *Bridges: A Work of Art and Engineering*. France: Setra, Government of France Publications.
- John Wiley & Sons. (2010). *Engineering Surveying: Theory and Examination Problems for Students*. ISBN 978-1-118-12172-6.
- Michel Virlogeux. (1980). *Structural Design of Bridges*. Head of the Concrete Bridge Division at Setra, France.
- Structural Engineering Institute (SEI). (2015). *Limit State Design of Steel Bridges*. ASCE Publications.
- SBG&P. (2019). *Kango Bridge Renovation Report*. Gabon : Société des Bâisseurs Gabonais et Ponts (SBG&P).
- Paulson, R. M. (2017). *Bridge Design and Maintenance: A Comprehensive Overview*. New York: McGraw-Hill Education.
- Engineering News-Record (ENR). (2015). *Modern Bridge Engineering: Materials and Techniques*. [ENR](#).

## APPENDICES

Appendix 1: Foundation pile

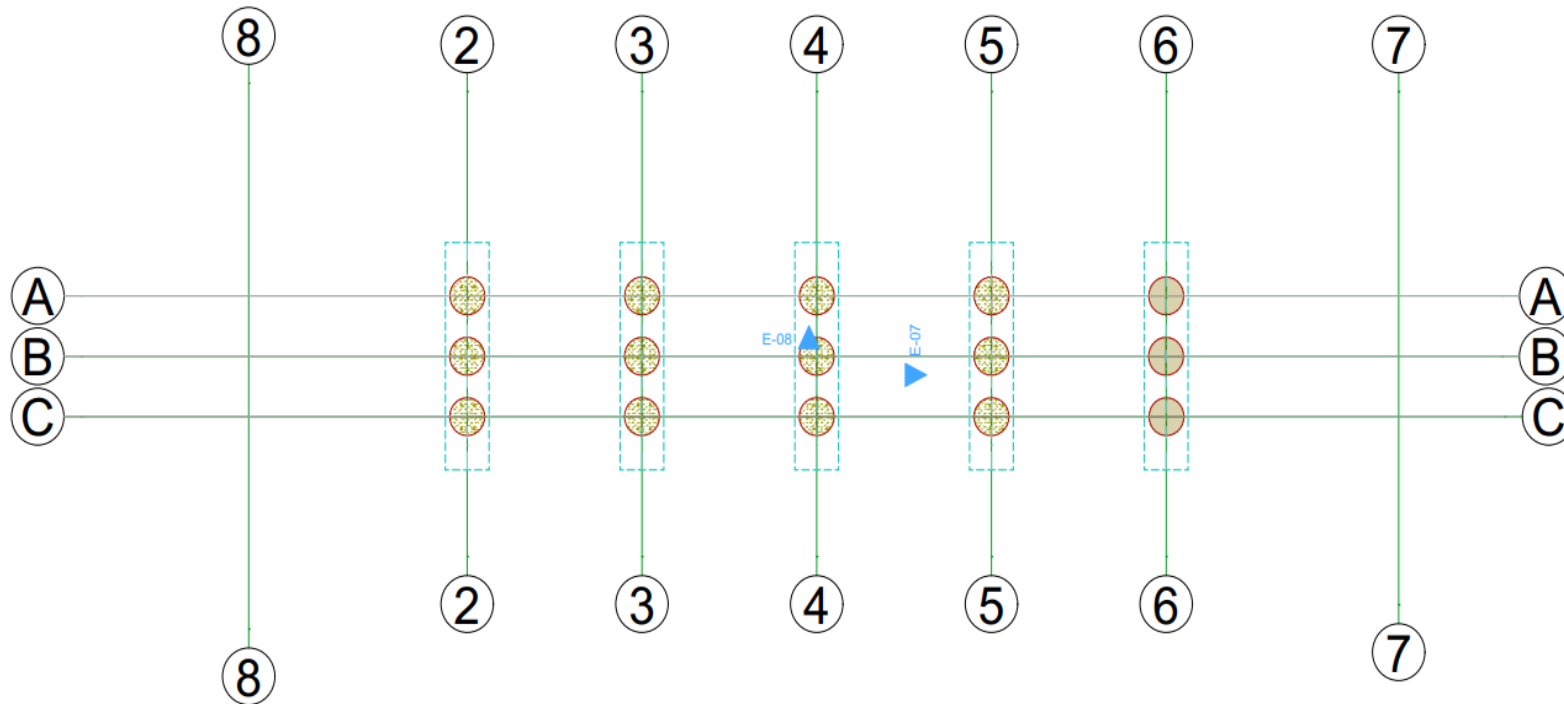


## Appendix 2: Foundation pile cap



Activat  
Go to Se

### Appendix 3: Big pile

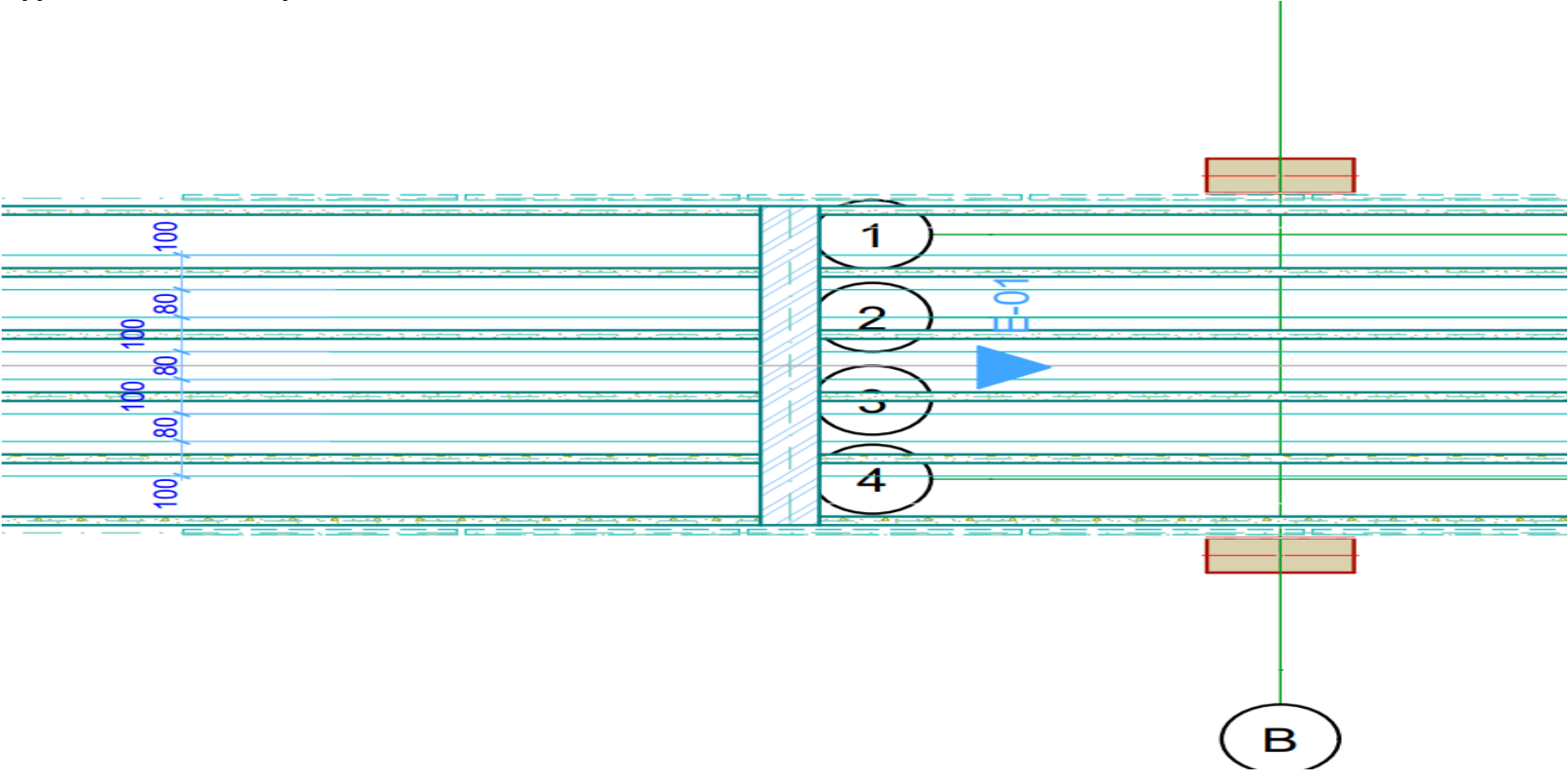


Activate Windows  
Go to Settings to activate

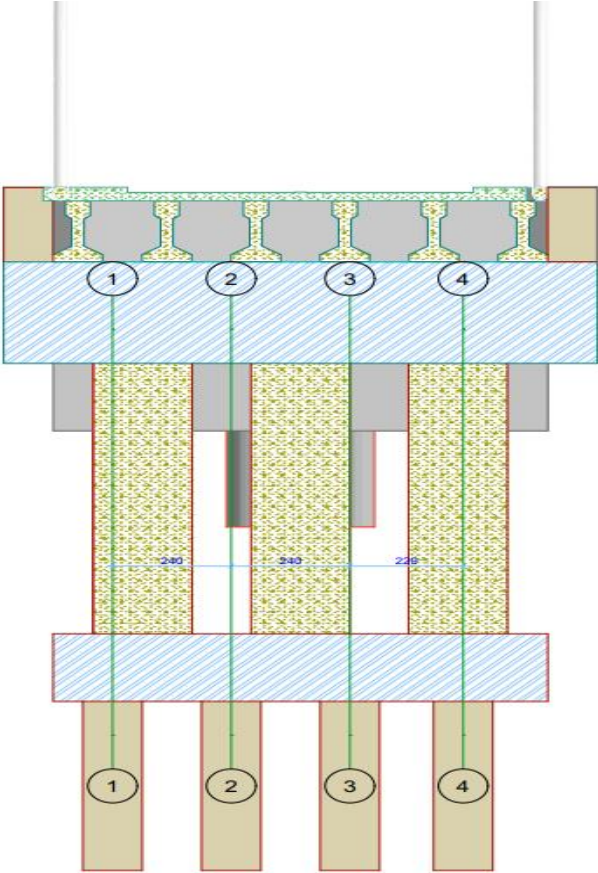
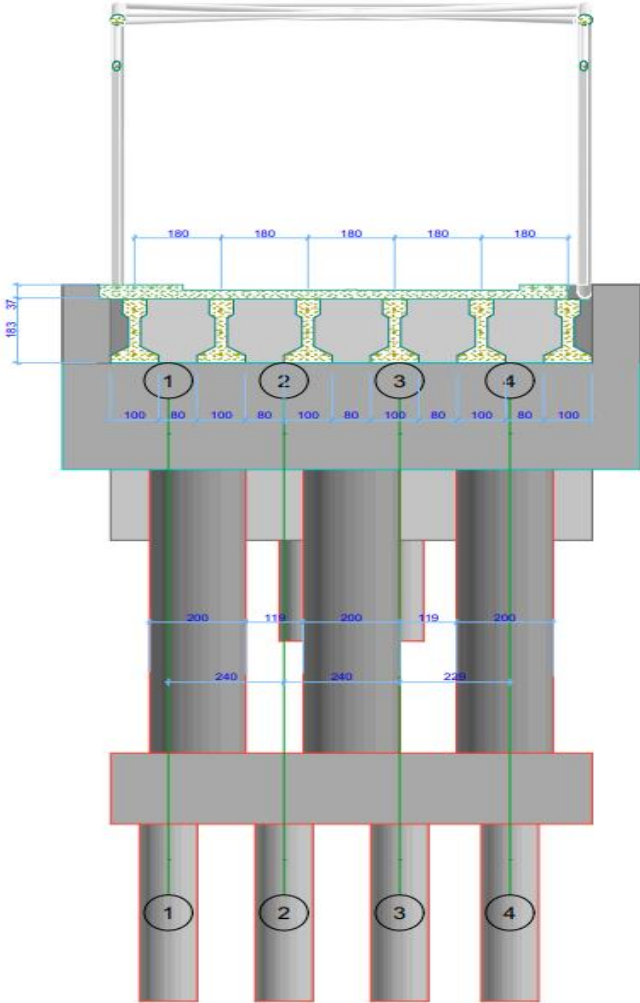




Appendix 4: Girds view plan



Appendix 5: Section of the bridge



**Appendix 6: Perspective of the bridge**

