

**REPUBLIC OF RWANDA**

**ULK POLYTECHNIC INSTITUTE**

**P.O.BOX 2280 KIGALI**

Website://[www.ulkpolytechnic.ac.rw](http://www.ulkpolytechnic.ac.rw)

E-mail: [polytechnic.institute@ulk.ac.rw](mailto:polytechnic.institute@ulk.ac.rw)

**ACADEMIC YEAR 2023-2024**

**DEPARTMENT OF CIVIL ENGINEERING**

**OPTION: CONSTRUCTION TECHNOLOGY**

**STRUCTURE DESIGN OF G + 3 COMMERCIAL BUILDING IN  
NYABUGOGO STATION KIGALI NYARUGENGE DISTRICT**

Submitted in partial fulfillment of the requirement for the advanced diploma in  
construction technology

**Presented by:** RUKERATABARO Carmel Carmel

**Roll number:** 202150154

**Under guidance of:** Eng. Bonaventure NKIRANUYE

Kigali, September 2024

**DECLARATION**

I, **RUKERATABARO Carmel Carmel**, declare that This research study is my original work and has not been presented for a Degree or any other academic award in any University or Institution of Learning". No part of this research should be reproduced without the authors' consent or that of ULK Polytechnic Institute.

Student name: RUKERATABARO Carmel Carmel

Signature: .....

Date.....

**CERTIFICATION**

I hereby certify that the research work for this project has been carried out under my supervision. I have gone through the final submission, and hereby approve it to be submitted in accordance with the requirements of ULK Polytechnic Institute.

Supervisor name: Eng. **Bonaventure NKIRANUYE**

Signature: .....

Date: .....

## **DEDICATION**

I dedicate my work

To the almighty and eternal God.

To my dear parents, **MASHAVU Brigitte, RUKERATABARO Jean marcel**, who have supported and encouraged me throughout my academic journey, I dedicate this work to you. Your unconditional love and constant support have been my strength and motivation. To my brothers and sisters, who have always been there for me, I dedicate this project to you. Your support and encouragement helped me persevere and achieves my goals. To my Friends, who are an important part of my family, I dedicate this work to you. Your support and friendship have been invaluable to me

## ACKNOWLEDGEMENT

My inspiration and my devotion to my studies comes back to me because I was the first to support myself and to believe in myself but apart from that I would like to thank my big brother Dave Rukeratabaro, who financed my studies, my father Rukeratabaro Jeans marcel, which was my greatest motivation he succeeded in making me improve more and more, my mother queen mother **MABUJA MASHAVU Brigitte** my greatest inspiration for all the livers where I want to give up she was my strength without saying a word I know that she supports me directly or indirectly ,Mom Cathy, my paternal aunt she is the only one who thinks of me of all my aunts she is the linker and she supported me throughout my years of study, Linda my big sister mom of Angel, I would have liked say a lot of things list all the things you have done for me but let me limit myself by the fact that you paid for my transport throughout my academic, Queenta Divine my sister she really support me in my studies and the greatest time she support me it was in my internship ,Nicolas Mulumba my friend for the starting time he was there until the end you are my partner for real, Angalikiyana Rosine, my best friend let me say that you are not my friend but my sister if I can try to explain to people the good parsons you are to me, to my family I suppose that am not going to say it in good way, my friends Teem Mobimba, the friends who supported me Yannick Balola ,Mulemangabo Don Elvis, Rwamankuba Celestin ,Ndeze Bonheur, Nzita Grace Ivan, Daniel, Christopher, Lydia Musavuli, Frank ,Joseph, my friend for long time As Abika Kalinda, Stephane Kana, Yurha Rukeratabaro, Tonton Claude, Mama Chouchou, Cinamula Cimamuka Phillipe, Hermine Sci, Angels Dad, Kahijuja

I would like also to thank my lecturer engineer Rukundo, engineer Bonaventure, Hod Annonce and others also my colleague wani Thadine, Shema, and others, you contributed as well as my studies were stressful.

I would like to thank you all because each of you has contributed directly or indirectly to my success today. I have the chance and the privilege of thanking you all as much as you are sure that I mentioned what I forgot, also thank you for your presence.

let me also thank ULK for the programs written for us for the education the training the value which was given thanks to him.

## **ABSTRACT**

This dissertation presents a detailed study titled "**Architectural and Structural Design of a G+3 commercial Building: Case Study of nyarungenge district**" The study focuses on a G+3 commercial building at nyabugogo station that measure 207,775m x 158,64m, comprising essential features like balconies, agency office, restaurant, shops, bus parking, kitchens, bathroom, offices. Each floor stands at a height of 4 m.

The structural analysis employed fundamental civil engineering principles to meticulously design key elements, including beams, slabs, columns, foundations, and stairs. Longitudinal beams, with a depth of 500 mm, width of 200 mm, and a flange width of 907 mm, utilized Ø16 mm reinforcement bars at both top and bottom. Slabs were diversified into three types (continuous and discontinuous), each with a 25 cm thickness and reinforced with Ø12 mm bars. Columns incorporated Ø25 mm bars with Ø8 mm links at 144 mm center to center.

Foundation design adhered to a bearing capacity ( $P_b = 350 \text{ KN/m}^2$ ), resulting in foundations measuring 1500\*1500\*500 mm, reinforced primarily with Ø20 mm bars. Stairs facilitating inter-floor access were crafted with a 265 mm going, 180 mm riser, 200 cm flight height, and a pitch of  $32.53^\circ$ . Reinforcement comprised Ø16 mm bars at the bottom and Ø8 mm bars at the top.

This dissertation offers a comprehensive exploration of the structural intricacies involved in designing a G+3 commercial building. Through meticulous analysis and design, it provides valuable insights into construction practices, particularly within the unique context of nyarungenge district.

**Keywords:** Structural design, G+3 commercial building, nyabugogo station, Beams, Slabs, Columns, Foundations, Stairs, Reinforcement bars, Civil engineering principles, architectural

## TABLE OF CONTENTS

<b>DECLARATION.....</b>	<b>I</b>
CERTIFICATION .....	II
<b>DEDICATION.....</b>	<b>III</b>
<b>ACKNOWLEDGEMENT.....</b>	<b>IV</b>
<b>ABSTRACT.....</b>	<b>V</b>
<b>TABLE OF CONTENTS .....</b>	<b>VI</b>
LIST OF TABLES .....	X
LIST OF FIGURES .....	XI
<b>LIST OF SYMBOLS AND ABBREVIATIONS .....</b>	<b>XII</b>
LIST OF APPENDICES.....	XIV
<b>CHAPTER 1: GENERAL INTRODUCTION.....</b>	<b>1</b>
1.0. Introduction of the study .....	1
1.1 Background of the study .....	1
1.2 Problem statement.....	2
1.3. Objectives of the study.....	3
1.3.1. Main objective .....	3
1.3.2. Specific objectives .....	3
1.4. Significance of the study.....	3
1.5. Personal Benefits .....	3
1.5.1. Academic Benefits .....	4
1.5.2 Socio-Economic Benefits.....	4
1.6 Scope and limitations of the study .....	4
1.7. Organization of the study.....	5
<b>CHAPTER 2. LITERATURE REVIEW .....</b>	<b>6</b>
2.0 Introduction.....	6
2.1. Preliminary design .....	6
2.1.1. Dead Load.....	6
2.1.2. Live Load (LL) .....	6
2.1.3 .Concrete .....	6
2.1.4. Design reinforcement.....	7

2.2. Foundations.....	7
2.3 .Beams.....	8
2.4 .Columns.....	10
2.5. Slabs.....	10
2.6. Ramps stairs.....	11
2.6.1. Ramp design steps.....	11
2.6.2. Types of stairs.....	11
2.6.3. Structural design elements.....	12
2.6.4. Construction details.....	12
2.7. Architectural design.....	13
2.7.1. Spatial planning.....	13
2.7.2. Lighting.....	13
2.7.3. Sustainability.....	13
2.7.4. Structural Integrity.....	13
2.7.5. Aesthetics.....	13
2.7.6. User Experience.....	13
2.7.7. Regulations and codes.....	14
2.8. Design Process.....	14
2.8.1 Conceptual Design.....	14
2.8.2 Schematic Design.....	14
2.8.3 Construction Documents.....	14
<b>CHAPTER 3.MATERIALS AND METHODS.....</b>	<b>15</b>
3.0 Description of the study area.....	15
3.1. Data Source.....	15
3.1.1. Primary Data.....	16
3.1.2. Secondary data.....	16
3.2. Design Considerations.....	17
3.2.1 Bending Reinforcement.....	17
3.2.2 .Shear Reinforcement.....	17
3.2.3 Column Design.....	18
3.2.4 Beam Design.....	18



3.3. Detailing of Reinforcement.....	18
3.4. Aggregates .....	19
3.4.1. Types of Aggregates .....	19
3.5 Additional Materials .....	20
3.6 Methods.....	20
3.6.1 Design Methodology.....	20
d standards specific to Rwanda.....	21
3.7 Structural Design .....	21
3.7.1 Load Calculations .....	21
3.7.2 Design of foundation.....	21
3.7.3. Design column .....	24
3.7.4 Design of beam .....	27
3.7.5 Design of slab .....	33
3.7.6 Design of Stair and Ramps .....	34
<b>CHAPTER 4.RESULTS AND DISCUSSIONS .....</b>	<b>36</b>
4.0 Introduction.....	36
4.1Design of slab .....	36
4.2 Design of beam .....	40
4.3.Design of column.....	43
4.4. Design of foundation /footing.....	48
4.5. Design of stairs .....	50
4.6. Design of ramp.....	54
<b>CHAPTER 5.CONCLUSION AND RECOMENDATIONS .....</b>	<b>57</b>
5.1. Conclusion .....	57
5.2. Recommendations.....	57
<b>REFERENCES.....</b>	<b>58</b>
<b>APPENDICES .....</b>	<b>59</b>
<b>Appendix 1) Basic span/effective depth ratio for rectangular or flanged beams.....</b>	<b>59</b>
<b>Appendix 2) Values of the coefficient <math>\beta</math> .....</b>	<b>59</b>
<b>Appendix 3) shear coefficient for uniformly loaded rectangular panel supported on four side .....</b>	<b>60</b>

<b>Appendix 4) Bending moment coefficient for uniformly loaded rectangular panel supported on four side .....</b>	<b>61</b>
<b>Appendix 5) Areas of groups of bars.....</b>	<b>62</b>
<b>Appendix 6) Bar spacing data.....</b>	<b>62</b>
<b>Appendix 7) Structural plans.....</b>	<b>63</b>
<b>Appendix 8) Sections.....</b>	<b>64</b>
<b>Appendix 9) Ground floor .....</b>	<b>64</b>
<b>Appendix 10) First floor .....</b>	<b>66</b>
<b>Appendix 11) Second floor .....</b>	<b>67</b>
<b>Appendix 12) Third Floor .....</b>	<b>68</b>
<b>Appendix 13) Views .....</b>	<b>69</b>

**LIST OF TABLES**

**Table 3.1: Percentages of area of steel minimum..... 29**  
**Table 3.2: Span to effective ratio table 3.9 of the code ..... 32**

## LIST OF FIGURES

<b>Figure 2.1: Types of beams according to load-bearing .....</b>	<b>9</b>
<b>Figure 3.1: Site location of proposed building station .....</b>	<b>15</b>
<b>Figure 3.2: Deep foundation.....</b>	<b>22</b>
<b>Figure 3.3 : Doubly reinforced beam .....</b>	<b>27</b>
<b>Figure 3.4: T Beam .....</b>	<b>28</b>
<b>Figure 4.1: Slab Panel.....</b>	<b>36</b>
<b>Figure 4.2: Slab reinforcement .....</b>	<b>40</b>
<b>Figure 4.3: Reinforcement of beam.....</b>	<b>41</b>
<b>Figure 4.4: Reinforcement bars of beam .....</b>	<b>43</b>
<b>Figure 4.5: Influence area .....</b>	<b>44</b>
<b>Figure 4.6: Direction of column.....</b>	<b>45</b>
<b>Figure 4.7: Footing sides.....</b>	<b>48</b>
<b>Figure 4.8: Footing reinforcements .....</b>	<b>50</b>
<b>Figure 4.9: Stair sections .....</b>	<b>51</b>
<b>Figure 4.10: Stair measurements.....</b>	<b>51</b>
<b>Figure 4.11: Detailing of stair .....</b>	<b>54</b>
<b>Figure 4.12: Detailing of ramp.....</b>	<b>56</b>

## LIST OF SYMBOLS AND ABBREVIATIONS

**$\beta_{sx}$  and  $\beta_{sy}$** : moment coefficients shown in Table 3.13 in BS 8110-1:1997

**$\beta_{sx}$  and  $\beta_{sy}$** : moment coefficients shown in Table 3.14 in 8110-1:1997

**$\beta_{vx}$  and  $\beta_{vy}$** : shear force coefficients shown in Table 3.15 in 8110-1:1997

**$A_{s \max}$** : maximum area of steel.

**$A_{s \min}$** : minimum area of steel.

**$A_{s \text{ prov}}$** : area of steel provided.

**$A_{s \text{ req}}$** : area of steel required

**BRC** – British Reinforced Concrete

**ULS** – Ultimate Limit State

**SLS** – Serviceability Limit State

**ACI** – American Concrete Institute

**$M_{sx}$** : bending moment in x direction

**$M_{sy}$** : bending moment in y direction

**$A_{sc}$** : area of steel in compression

**$A_{sv}$** : area of steel in vertical links

**G+3** – Ground plus three floors

**Max**: maximum

**W/C** – Water-Cement Ratio

**$f_{cu}$** : characteristic strength of concrete.

**$M_x$** : moment on the column in x direction

**$M_y$** : moment on the column in y direction

**RC** – Reinforced Concrete

**LL** – Live Load

**DL** – Dead Load

**BS** – British Standards

**$F_y$**  – Yield Strength of Steel

**$F_c$**  – Compressive Strength of Concrete

**$E_c$**  – Modulus of Elasticity of Concrete

**As** – Area of Steel Reinforcement

**Qk**: characteristic imposed load.

**Gk**: characteristic dead load.

**VC**: Shear capacity.

**Ac**: total area of concrete

**As**: minimum recommended area of reinforcement.

**bw**: average web width of a flanged beam

**$\beta$ b**: the ratio of redistributed moment over elastic analysis moment

**$\gamma$ m**: partial safety factor for the strength of material

**$f_y$** : characteristic strength of reinforcement.

**$\gamma_f$** : partial safety factor for load

**lx**: length of shorter side.

**ly**: length of longer side

**hf**: thickness of the flange.

**M**: design ultimate moment at the section considered.

**N**: design axial force.

**W**: Design shear force due to ultimate loads.

**Z**: lever arm

**W**: Design shear force due to ultimate loads.

**Z**: lever arm

**V**: Shear stress

**b**: width or effective width of the section or flange in the compression zone.

**d**: effective depth of the tension reinforcement.

**$\phi$** : diameter of steel.

**l**: span of the beam.

**h**: overall depth of the cross-section of a reinforced member.

## LIST OF APPENDICES

Appendix 1) Basic span/effective depth ratio for rectangular or flanged beams.....	59
Appendix 2) Values of the coefficient $\beta$ .....	59
Appendix 3) shear coefficient for uniformly loaded rectangular panel supported on four side ...	60
Appendix 4) Bending moment coefficient for uniformly loaded rectangular panel supported on four side .....	61
Appendix 5) Areas of groups of bars.....	62
Appendix 6) Bar spacing data.....	62
Appendix 7) Structural plans .....	63
Appendix 8) Sections.....	64
Appendix 9) Ground floor .....	64
Appendix 10) First floor .....	66
Appendix 11) Second floor.....	67
Appendix 12) Third Floor.....	68
Appendix 13) Views .....	69

## **CHAPTER 1: GENERAL INTRODUCTION**

### **1.0. Introduction of the study**

This Chapter provides a comprehensive background of the study, the problem statement, the main objective, the specific objectives, the significance of the study, scope and limitations and the organization study.

### **1.1 Background of the study**

Bus stations are one part of the global travel circuit. In large parts of the world, buses are part of public transport in many countries, especially in developing countries where rail and air transport is less available in the rapid process of urbanization across the globe, the demand for functionality, ecological consideration, and appropriate designing of bus terminals to meet the higher passenger traffic is on the rise. The bus stations of these days are combined with smart technologies, displaying real-time information along with enhanced security. In the world nowadays, there is an increasing demand for greener transport solutions. This calls for the need to use public transport as a way to reduce carbon emissions and congestion in cities. This can be done by constructing bus terminals or stations. (Aggarwal,2004).

In Africa, buses are the major source of public transportation. Most of these modes of transport are prominent in Sub-Saharan Africa. The bus stations are normally centering of economic activities since this helps in trade and daily travel to and from work. Most bus stations across the continent face challenges characterized with overcrowding, inadequate facilities, and poor maintenance. However, a growing development in the process of modernizing the facilities proxy's investments of some of the cities in BRT systems and terminal upgrades. These bus terminals are also important in developing projects of regional integration like the African Continental Free Trade Area, as they allow for transboundary movement of goods and people. (African Union2015)

The East Africa region relies greatly on the bus station for its inter-city and cross-border travel. Major bus terminals in cities like Nairobi, Dar es Salaam, and Kampala connect travelers to other parts of the region. Bus stations contribute to the local economy by providing business opportunities to small-scale operators and a source of employment. Transportation infrastructure is being developed and improved, including but not limited to upgrading bus stations and facilities,



to cater for rapidly growing urban centers within the region. The two Bus terminals in Rwanda form part of a key nodal point in the transport network, linking Kigali with the rest of the country and the neighbors. (EAC Secretarial 2021)

The government of Rwanda has been embarking on improvements in infrastructure related to public transport, upgrading bus stations to meet the increasing demand by passengers and raising the service quality. In Rwanda, with its development, the concept of the bus station is increasingly becoming central to broader urban planning strategies focusing on mitigation of congestion, sustainable mobility, and in general enhancing the urban experience. Nyabugogo Station in Kigali is one of the busiest bus terminals in Rwanda; it acts as an interchange for the citizens within the country, other local travelers, and even international ones. It connects Kigali with various parts of Rwanda to other neighboring countries like Uganda and Tanzania. (Rwanda vision2020)

Nyabugogo Station faces some key issues with overcrowding, shortage of amenities, and traffic congestion. The redevelopment project will ensure that building a modern multi-purpose commercial building with integrated transportation and commercial activities takes care of the challenges for efficiency while passengers experience it. The redevelopment of Nyabugogo Station represents an extendable dimension in the bigger positive efforts of Kigali to improve its urban mobility, reduce congestion, and promote more public transport as a sustainable alternative to using private cars. (city of Kigali 2020)

## **1.2 Problem statement**

Urban public transportation infrastructure in Kigali, particularly at Nyabugogo Station, faces significant challenges in terms of efficiency and service delivery. Nyabugogo is a key transportation hub, serving both intercity and local commuters; however, its outdated infrastructure is no longer adequate to support the increasing volume of passengers. The station's current design results in overcrowding, inefficient traffic flow, and insufficient passenger amenities, which contribute to long waiting times, discomfort, and safety concerns for travelers. Additionally, the surrounding swampy area exacerbates the problem by posing challenges to both infrastructure stability and expansion. The absence of modern facilities, such as digital ticketing systems, organized parking, and accessible commercial spaces, further limits the station's ability to meet growing demands. Without a strategic redevelopment plan, Nyabugogo Station will continue to

face these operational inefficiencies, negatively affecting the city's transportation system and economic growth. Therefore, addressing these structural and design limitations is crucial for improving urban mobility, passenger satisfaction, and overall infrastructure sustainability.

### **1.3. Objectives of the study**

#### **1.3.1. Main objective**

The main objectives of this project were and structural design of G + 3 commercial building in Nyabugogo station.

#### **1.3.2. Specific objectives**

- To provide the plan view, perspectives, elevations, cross sections of building;
- To design the critical building members in order to check if the building is safe;
- To calculate loads taken down on the column
- To prepare structural plan and structural details for structural elements.

### **1.4. Significance of the study**

The redevelopment of the Nyabugogo Station in Kigali is a critical infrastructure project aimed at improving the functionality, aesthetics, and overall efficiency of one of the city's busiest transit hubs. This study will explore how modern design principles, particularly in commercial buildings and reinforced concrete structures, can contribute to urban renewal and economic growth. By incorporating sustainable design practices, this project will also address environmental concerns. The use of reinforced concrete with sustainable materials and energy-efficient designs can significantly reduce the carbon footprint of the new structures, setting a benchmark for future projects in Kigali and beyond.

### **1.5. Personal Benefits**

Engaging in this project will enhance your technical and professional skills, particularly in architectural design and civil engineering. You will gain hands-on experience in designing commercial buildings and working with reinforced concrete, which are essential skills in the construction industry.

Successfully completing this study will position you as an expert in urban redevelopment projects, potentially opening doors to career opportunities in both the public and private sectors. It will also build your portfolio, showcasing your ability to handle complex construction projects.

### **1.5.1. Academic Benefits**

This study will contribute to the academic community by providing a comprehensive case study on the redevelopment of a major urban transit hub. It will offer valuable insights into the challenges and solutions associated with such projects, particularly in the context of a developing city like Kigali.

Your work will serve as a foundation for further research in the fields of architecture, civil engineering, and urban planning. It will encourage innovation in the design and construction of commercial buildings, promoting the use of advanced materials and techniques.

### **1.5.2 Socio-Economic Benefits**

The redevelopment of Nyabugogo Station will stimulate economic activity in the area, creating jobs and attracting businesses. The new commercial buildings will provide spaces for retail, offices, and other commercial activities, boosting the local economy.

The project will enhance the quality of life for residents and visitors by providing a modern, efficient, and aesthetically pleasing environment. Improved infrastructure will lead to better transportation options, reducing traffic congestion and improving accessibility.

### **1.6 Scope and limitations of the study**

This project will focus on the analysis of the structure safety of the building as well as doing of the following elements:

- Plans view
- Structural plans
- Foundation
- Slabs
- Beams
- Column and stairs

Has the conception of the building is large domain involving different spleen that cannot be covered within a limited time this project not treat that following:

- Soil analysis
- The electrical plumbing and internet installation works
- cost estimation of the project

## **1.7. Organization of the study**

This report has five chapters:

### Chapter 1: General Introduction

Guides the reader to get the idea of what the study is all about, it contains the background of the research problem and also clarifies the objectives of this study.

### Chapter 2: Literature review

This chapter contains theoretical aspects and describe in detail different parts of the building to be studied in this research

### Chapter 3: Materials and Methods

This chapter describe the study area and given the overview and describe the material and method in details of the drawings of the buildings

### Chapter 4: Result and Discussions

This chapter is the main and the biggest chapter in this this dissertation, this chapter describe the structure analysis of different parts of the building slab, beams, column, foundation, stairs and ramp their respective reinforcement

### Chapter 5: Conclusion and Recommendation

This chapter closes the report by providing a brief overview of the contains in this report and give the conclusion to the result obtained in chapter 4 and also giving me recommendation to those results

## **CHAPTER 2. LITERATURE REVIEW**

### **2.0 Introduction**

This chapter focuses on the review of the literature on design and concept of a commercial building of three storied and the related literature. In this particular research the literature mainly bases on what different authors have written about structural and architectural design of a commercial building. The purpose of this literature review is to identify gaps which were left out by different authors to widen the understanding of architectural and structural design of a commercial building.

### **2.1. Preliminary design**

**Load Estimation:** Estimation of dead loads, being permanent or static loads that the building will carry, and live loads that can be described as temporary or movable. Other loads, and snow, depending on the location are also included. (Eurocode, 1991)

**Material selection:** The concrete, steel, wood, or composite can be selected based on the requirement that would be strength, durability. (ACI, 2019).

**Structural System Selection:** Determine the structural system type according to building height, function, and loads, such as framed structure, shear wall structure, or truss structure.

#### **2.1.1. Dead Load**

Self-weight of the structure includes the weight of all permanent components of the structure, such as beams, columns, slabs, walls, floors, and fixed equipment. (BS, 1996)

#### **2.1.2. Live Load (LL)**

It consists of the temporary or movable loads that the structure may be called upon to support: for example, people, furniture, vehicles, and other movable items. In a commercial building, live loads would involve the weight of occupants, office equipment, and possibly parking loads, if applicable. (BS, 1996)

#### **2.1.3 .Concrete**

Concrete is the homogenous mixture of binder (cement) fine aggregate coarse aggregate and water sometimes admixtures.

Fine aggregate (sand) are those aggregate which pass through a 4.55mm sieve opening.

Coarse aggregate (gravel) crushed stone coarse aggregate are those aggregate which are retained on 4.75mm sieve opening.

In order to achieve the desired compressive strength of concrete the quantity of water should be measured and respected, to get the quantity of water to be added, we should consider that the quantity of water is the product of the quantity of cement and water cement ratio (w/c).

(ACI, 1997)

Admixture is a material ingredient of concrete which is added in the concrete for specific reasons.

Requirement mix ratio

Ex: 1:1:2

In order to achieve the desired compressive strength, the same weighing batching tool should be used. (ASTM, 2019)

#### **2.1.4. Design reinforcement**

Reinforcement bars are found into 3 type

Hot rolled mild steel with characteristic strength ( $f_y$ )=250N/mm<sup>2</sup> mild steel has smooth surface

Hot rolled or worked high yield steel with characteristic strength ( $f_y$ ) of 460N/mm<sup>2</sup> and young modulus (E) of 200 KN/mm<sup>2</sup>

Fabric mesh is made by steel which are jointed /welded together to form a mesh with characteristic strength ( $f_y$ ) of 460N/mm<sup>2</sup>, (BS, 2005).

#### **2.2. Foundations**

Foundations are the foundation of any building and are essential to ensure the stability and durability of the structure, Foundation Design Steps: Soil Investigation, Analysis of soil properties in Nyabugogo to determine its bearing capacity. Foundation Types is Choice between shallow foundations (slab foundations or isolated footings) and deep foundations (piles) based on the results of the soil investigation, Pile foundations should be used when shallow foundations are inadequate to support the loads or when soil conditions pose challenges for stability and settlement control calculation of foundation dimensions to support the building loads based on local and international standards, Selection of appropriate construction materials (high strength concrete, reinforcing steel),(BS, 1986).

Foundation is the lowest part of the building that supports loads from upper part of the building and distribute them on the soil loads should be avoid failure of the building (unequal settlement of the building)

Deep foundation: is the foundation where by depth of foundation over base of the foundation must be greater than 2; total load on foundation =  $1.0G_k + 1.0Q_k + w$

Area of the foundation = total load on foundation / bearing capacity of the soil

Bearing capacity of the soil is the ability of the soil to withstand upper applied loads; the bearing capacity of the soil < maximum pressure; the bearing capacity of the soil is determined using different methods among those methods, we have dynamic cone penetrometer test

Size of footing is determined as follows: for square footing the size of footing = square roots of area of the footing.

For rectangular footing, the size of the footing is obtained by dividing the assumed size into the area of footing.

If design stress > bearing capacity the foundation is not safe

If design stress < bearing capacity the foundation is safe. Ko

If the foundation is unsafe different decisions may be taken

Consider the depth where bearing capacity is maximum

Soil stabilization

Resizing footing

If  $Q_f < R_b \cdot A_b$ , the foundation is not safe with respect to punching shear

Conclusion: thickness of the footing should be increased, (Eurocode, 2004).

### **2.3 .Beams**

Beams support the loads from the slabs and transfer them to the columns, beam design steps, Applied Loads Identification of dead loads and live loads, beam dimensions, Calculation of the cross-section required to support the applied loads, considering bending and shear stresses.

Reinforcement: Arrangement of reinforcing bars to resist bending moments and shear forces.

#### **Type of beam according to load -bearing**

Primary beams: primary beams are beams which are directly supported by columns; Great span: primary beam which has long span; support main structure /main element like floor slab and roof; load transfer: primary beams support load from floor and roof and distribute them on the columns.

Secondary beams: secondary beams are beams which are supported by primary beams; short span: secondary beams have short span compared to primary beam; support no structure element: secondary beam is designed to carry no load bearing structures live partition wall or no -load bearing wall at all; load transfer: secondary beam transfer load to primary beams.

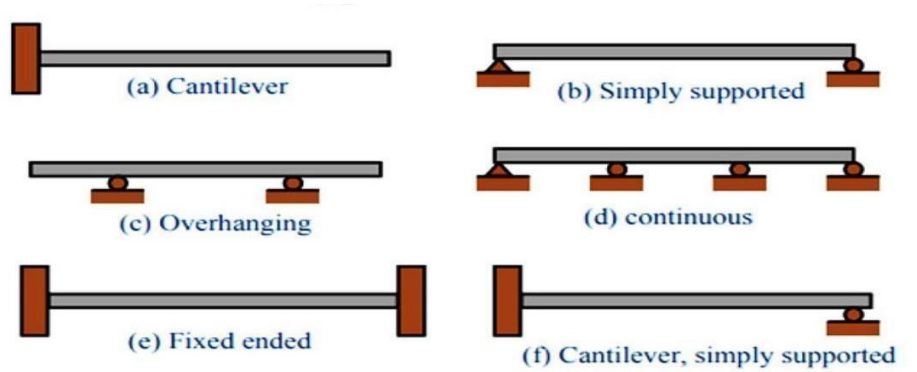

Figure 2.1: Types of beams according to load-bearing

### Type of beams according to their supports

### Type of beam according to amount of reinforcement

- Over reinforced beam
- Under reinforced beam
- Balance beam

### Type of beam section

- Rectangular beam

Singly reinforced rectangular beam reinforcement parts are in the bottom of beam section (tension zone) only there are no reinforcement bars in the top of beam or there are minimum reinforcement bars to control cracking. (BS, 2004).

Doubly reinforced rectangular beam reinforcement bars in the bottom (tension zone) and in top (compression zone) of beams

Condition:  $M_u > M_{RC}$ ;  $k > k_{bal}$

The intention /main goal of designing beam section is to find out the area of steel needed condition  $A_{Smin} < A_S < A_{Smax}$

If  $M_u < M_{RC}$ , no compression bars required

If  $M_u > M_{RC}$ , compression bars required

Where  $M_u$  = ultimate moment /maximum moment

$M_{RC}$  = moment of resistance of concrete

If  $k < k_{bal}$ , no compression bars required

$k > k_{bal}$ , compression bars required



## 2.4 .Columns

Columns are the vertical members that transfer the loads from the beams and slabs to the foundations.

Column Design Steps: Vertical Loads: Calculation of the total vertical loads that each column must support.

Column Dimensions: Determination of the cross-section of the columns to avoid buckling and ensure stability.

Reinforcement: Placement of longitudinal reinforcement and stirrups to resist compressive and shear forces.

Code classifies column into two type:

- Short column
- Slender column

Short column is when  $l_{ex}/h$  and  $l_{ey}/b$  is less than 15 for braced column and less than 10 for unbraced column

$l_{ex}$ =effective height with respect to major axis

$l_{ey}$ =effective height with respect to minor axis

$h$ = width of column

$b$ = breadth of column

$l_e = \beta l_0$ , where  $\beta$ = coefficient that depend on end condition ( $0,75 < \beta < 1$ )

Table 19 and 3.20 shows the value of  $\beta$  for braced column and unbraced column respectively in order to control cracking in the column  $\beta$  should be depends to  $N/bhfc_u$  This value is found in table 3 to 2 of the code

$A_{smin} = 0,4 * A_c$ ;  $A_{smax} = 6 * A_c / 100$

To make sure that Link should not be less than 6 mm or a quarter Of Maximum diameter of many bars; the spacing should not be greater than 12 times the maximum diameter of main bars. (ACI, 2019).

## 2.5. Slabs

Slabs form the floors and ceilings of the building.

### Slab Design Steps

Applied Loads: Determination of dead loads (self-weight) and live loads.

Slab Thickness: Calculation of the minimum thickness required to avoid excessive bending and deformations.

Reinforcement: Placement of reinforcing bars to resist bending moments and shear forces.

That is, horizontal flat structures elements that are provided as a cover of floor or the building slab support different loads such as itself.

### **Type of slab**

one-way slab= slab spanning in One Direction

two-way slab= slab spanning into directions

flat slab= a slab which is supported by column and beam without intermediate beam

### **Condition**

if  $l_y$  over  $LX < 2$  the slab is it two-way slab

if  $l_y$  over  $LX > 2$  this slab is the one-way slab

The thickness of this slab is running between  $LX$  over 20 and  $lx/40$

## **2.6. Ramps stairs**

Ramps are essential for vehicular and pedestrian access, especially in a commercial setting.

### **2.6.1. Ramp design steps**

Ramp Slope: Determination of the slope based on safety and accessibility standards.

Ramp Dimensions: Calculation of the width and length to ensure smooth passage.

Reinforcement: Arrangement of reinforcements to support dynamic loads from vehicles and pedestrians.

For the design of stairs, focusing on reinforced concrete techniques, here are some key considerations:

### **2.6.2. Types of stairs**

Straight Stairs: Common in buildings with limited space.

Spiral Stairs: Used for aesthetic purposes and in areas with restricted space.

Dog-Legged Stairs: Two flights of stairs running in opposite directions with no space between them.

Open-Well Stairs: Similar to dog-legged stairs but with space between the flights.

### **Components of Stairs**

Tread: The horizontal part where the foot is placed.

Riser: The vertical part between the treads.

Stringer: The inclined member supporting the treads and risers.

Landing: The flat area between two flights of stairs.

### **Design Consideration**

Tread-Riser Ratio: Typically, the sum of the tread and twice the riser should be between 600mm and 650mm.

Staircase Width: Depends on the type of building but generally not less than 1.0m for residential buildings and 1.5m for public buildings.

Headroom: Minimum headroom should be 2.1m to avoid discomfort.

Slope: The slope of stairs is generally between 25° and 40°.

### **2.6.3. Structural design elements**

Load Consideration: Include dead load (self-weight of stairs) and live load (people using the stairs).

#### **Reinforcement Detailing:**

Main Reinforcement: Placed at the bottom of the staircase to resist tension. Use bars of adequate size depending on the load.

Distribution Bars: Placed at the top surface perpendicular to the main reinforcement.

Formulas for Structural Design:

Step Height (Riser) Calculation:  $h = \text{Total Rise} / \text{Number of Risers}$

Tread Length Calculation:  $t = \text{Total Going} / \text{Number of Treads}$

Reinforcement Calculation:

Bending moment for stair slab:  $M = wL^2/8$

Area of steel reinforcement:  $A_s = M / f_y \times j \times d$

Shear Design: Ensure that the design shear force is within the permissible limits of concrete shear strength.

### **2.6.4. Construction details**

Formwork: Should be properly supported to hold the concrete in place until it gains sufficient strength.

Concrete Mix: Usually, a mix ratio of 1:2:4 (cement: sand) is used for stairs, but this might vary based on specific project requirements.

Curing: Proper curing is essential to ensure the durability and strength of the staircase.

## **2.7. Architectural design**

**Form:** The shape, appearance, and overall aesthetic of the building.

**Function:** Use of the building. Architects are responsible to provide spaces that meet needs and are useful to those who would be using it. (*IBC 2021*).

### **2.7.1. Spatial planning**

This involves the organization of spaces within a building to ensure that space is utilized efficiently and movement between spaces is smooth.

This includes floor plan design, circulation routes-like hallways, stairs, and elevators-and the relations between areas, such as public versus private.

### **2.7.2. Lighting**

Artificial and natural lighting is of great significance during architectural designing.

Daylighting strategies, the orientation of the building, and window placement for maximum interior light.

Artificial Lighting: Design enhances the mood, function, and aesthetic of spaces.

### **2.7.3. Sustainability**

Incorporating ecological-friendly habits within a building, including energy-efficient systems, sustainable materials, and designing for minimal environmental impact.

Green architecture can feature solar panels, rainwater harvesting, and green roofs.

### **2.7.4. Structural Integrity**

The design must be such that the building can carry its loads and resist various environmental forces like wind, earthquakes, and weather. It should look pleasing to the eye.

They are structural elements-beams, columns, foundations, among others-which must be designed to maintain the stability of the building safely.

### **2.7.5. Aesthetics**

Architectural design also encompasses the artistic expression of the building in style, for instance, modern, classic, industrial; the proportions; and the overall visual harmony.

The design, inside and outside, is by the look and feel one wants to portray: sleek and modern, warm and traditional, bold and innovative.

### **2.7.6. User Experience**

Design the spaces to be functional yet comfortable and pleasant for users.

Consider ergonomics, accessibility, and ambiance-ramps instead of stairs, wide doors for wheelchair access.

#### **2.7.7. Regulations and codes**

It has to meet the local building code, safety regulations, zoning laws, and accessibility standards. The designs should strictly adhere to the architects in all legal respects regarding permits that will be required for them to begin construction.

### **2.8. Design Process**

#### **2.8.1 Conceptual Design**

This is the first stage where the architect provides a rough picture of the design he has in mind. It involves sketches, mood boards, and simple models.

#### **2.8.2 Schematic Design**

The architect creates more advanced drawings, like floor plans and elevations. Refine the design concept; study the project for feasibility.

#### **2.8.3 Construction Documents**

Construction drawings and specifications are created in detail. These documents direct the builders and ensure that the design is executed according to plan.

## CHAPTER 3. MATERIALS AND METHODS

### 3.0 Description of the study area

The proposed site for this project was located in Nyarugenge district, Muhima sector,



Figure 3.1: Site location of proposed building station

#### 3.1. Data Source

The architectural drawings and designs of the G+3 commercial building was obtained and studied in minute detail to understand the layout, dimensions, and specifications from the viewpoint of an architect. Detailed discussions with the architects and builders present on the project were held to understand the aesthetic requirements and unique design considerations.

Historical climate information, which included weather patterns and recorded wind speeds for Nyarugenge district, was also obtained from relevant meteorological sources. This information proved important in making realistic estimates of the wind loads, which are fundamental in the structural design process.

Besides site-specific information, a critical literature review was done to understand the best practices and new approaches towards the design of multi-story buildings. Various scholarly

articles, research papers, and textbooks were studied in order to understand state-of-the-art developments in the field of structural engineering so that the design reflected modern approaches that were within accepted industrial standards and codes.

Consultations were also made with experts in the field, including seasoned structural engineers. This provided an excellent source of qualitative data through on-field insights and expert opinions on the issues and considerations involved in putting up multi-story buildings in the Nyarugenge district

This data formed the basis for designing the structure. Generally, attention to detail, follow-through with standards, and an integrated approach to data collection helped to ensure that the conclusions and recommendations of the dissertation were valid and scientifically sound.

### **3.1.1. Primary Data**

The researcher has used primary data for this study as original data collected by the researcher from the population.

The main instrument used for the collection of data was the questionnaire, which was directly administered to the respondents by the researcher and the assistants. The kind of questions used in the questionnaire were mainly structured in nature; that is, closed-ended, for ease of administration and analysis. Field data obtained by the following tools:

- Direct interview and enquiries from the owner of the houses
- Carrying out site visits for on the spot observation and direct observation on existing facilities.
- Taking photographs of such visited existing facilities and producing diagrams for illustrative purposes of such.

### **3.1.2. Secondary data**

Data sources may be either primary or secondary. In this case, the secondary source of data involves information obtained from research work already conducted that is relevant to the study. Information was sourced from textbooks, reports, journals, and electronically published maps, Google maps, Orthophotos. This data was obtained from already executed work in this field of studies. The sources of information included: Textbooks relevant to the research topic Past thesis and project works Sessional papers

- Newspapers and Journal
- Use of the internet for further information and data collection.

- Internationally recognized and accepted research encyclopedia

### 3.2. Design Considerations

The design of steel reinforcement is crucial to ensure the structural integrity and load-bearing capacity of the building. The following subsections provide a detailed explanation of the design considerations and calculations involved.

#### 3.2.1 Bending Reinforcement

**Moment of Resistance (Mr.):** The moment of resistance for a reinforced concrete section can be calculated using the following formula

$$\text{where: } Mr = A_s \cdot f_y \cdot d \left( 1 - \frac{A_s \cdot f_y}{f'_c \cdot b \cdot d} \right)$$

$A_s$  = area of steel reinforcement

$f_y$  = yield strength of steel

$d$  = effective depth of the section

$f'_c$  = compressive strength of concrete

$b$  = width of the section

**Area of Steel (A\_s):** The required area of steel reinforcement can be calculated based on the bending moment (M) and the moment arm (z):

$$A_s = M / (0.95 \cdot f_y \cdot z)$$

Where:

$M$  = ultimate moment

$z$  = lever arm, typically taken as  $0.95d$  for singly reinforced sections.

#### 3.2.2 .Shear Reinforcement

**Shear Capacity (Vr):** The shear capacity of a reinforced concrete section is provided by both the concrete and the steel stirrups. The total shear capacity can be calculated using:

$$V_r = V_c + V_s$$

Where:

$V_c$  = shear capacity of concrete

$V_s$  = shear capacity of steel stirrups

Shear Capacity of Concrete ( $V_c$ ): This is given by:

$$V_c = 2 \cdot \sqrt{f'_c} \cdot b \cdot d$$



**Shear Capacity of Steel ( $V_s$ ):** The shear capacity provided by steel stirrups is:

$$V_s = (A_v \cdot f_y \cdot d) / s$$

where:

$A_v$  = area of shear reinforcement (stirrup) per unit length

$s$  = spacing of stirrups (in)

### 3.2.3 Column Design

- **Axial Load Capacity ( $P_u$ ):** The axial load capacity of a reinforced concrete column can be calculated as:

$$P_u = 0.95 \cdot f'_c (A_g - A_s) + f_y \cdot A_s$$

Where:

$A_g$  = gross area of the column

$A_s$  = area of steel reinforcement

- **Interaction Diagrams:** For combined axial and bending loads, interaction diagrams are used to determine the capacity of columns, considering both axial and moment capacities.

### 3.2.4 Beam Design

- **Flexural Design:** The flexural capacity of beams is determined using the moment of resistance formula mentioned above. The design ensures that the provided reinforcement can withstand the maximum moments experienced by the beam.
- **Shear Design:** Similar to columns, beams also require adequate shear reinforcement to resist shear forces. The design of stirrups is based on the calculated shear forces.

### 3.3. Detailing of Reinforcement

- **Rebar Placement:** Proper placement of rebar is essential to ensure the structural performance of concrete elements. This includes maintaining adequate cover, spacing, and alignment.
- **Splicing and Lapping:** Rebar's are often spliced or lapped to achieve the required lengths. The lap length ( $l_s$ ) can be calculate using

$$L_s = (d_b \cdot f_y) / (4 \cdot \sqrt{f'_c})$$

Where:

$d_b$  = diameter of the bar

$f_y$  = yield strength of steel

$f'_c$  = compressive strength of concrete

### **3.4. Aggregates**

Aggregates are one of the essential constituents of concrete and occupy 60-75% of concrete volume; hence, they become very significant in determining the properties of concrete, which include strength, durability, and workability. This section provides an in-depth review of the sources, properties, quality control measures, and types that the aggregates to be used in the Nyabugogo Station redevelopment project are expected to have.

#### **3.4.1. Types of Aggregates**

##### **Coarse Aggregates:**

Description: Coarse aggregates are composed of either gravel, crushed stone, or recycled concrete. They are generally larger in diameter than 4.75 mm.

Types: In this work, a mixture of crushed stone and gravel has been utilized.

Crushed Stone: The stone is produced from hard, dense rocks such as granite or limestone.

Gravel: Naturally rounded particles, derived from riverbeds or quarries.

Size and Gradation: Aggregates are classified based on their sizes to offer the concrete mix proper packing and fewer voids. Common sizes are aggregates of 10 mm, 20 mm, and 40 mm.

##### **Fine Aggregates:**

Description: Fine aggregates are the one composed of natural sand or crushed stone dust, smaller than 4.75 mm diameter.

Types: In the present work, river sand and M-sand (manufactured sand) have been used.

River Sand: Naturally available sand, most often extracted from riverbeds; characterized by its smooth texture with rounded particles.

Manufactured Sand: Produced by crushing rocks, providing a rougher texture that improves bond with cement paste.

### **3.5 Additional Materials**

There are other materials needed for the construction of the modern 3 + G commercial building at Nyabugogo Station, aside from the primary ones. These materials also play significant roles in ensuring that the structure is going to be durable, functional, and aesthetic.

### **3.6 Methods**

#### **3.6.1 Design Methodology**

Design methodology adopted for the redevelopment of Nyabugogo Station involves a sequential approach to architectural and structural design. This section elaborates the various processes and tools employed to ensure a commercial building of functionality, aesthetically pleasing output and its structural soundness.

#### **3.6.2 Architectural Design**

##### **Site Analysis**

**Contextual Study:** Observe the environment, existing infrastructure, and socio-economic factors around.

**Zoning and Regulations:** Check municipal zoning ordinances, building codes, and environmental regulations for restrictions on the proposed development.

##### **Conceptual Design**

**Vision and Objectives:** Establish the overall vision of the project, defining its functional, aesthetic, and sustainable objectives.

**Sketches and Models:** Initial sketches will be done along with physical or digital models of the design concepts to start looking at the design work.

**Consultation with Stakeholders:** Consult all stakeholders, be it local authorities, future tenants of the building, or the community where the development is to be located, to seek their feedback on the design.

##### **Preliminary Design**

**Space Planning:** Detailed floor plans that indicate space allocations for different functional areas. Then, elevation and section drawings that define vertical dimensions and architectural features. Next, durable, aesthetic materials will be selected for the construction process, considering sustainability.

##### **Final Design Development**

**Detailed Drawings:** Full architectural drawings on floor plans, elevations, sections, detailed views.

3D Modeling: Development of detailed 3D models using Revit or Sketch Up for enhanced visualization and presentation.

Interior Design: Designing interior spaces to include furniture layouts, lighting, and finishes for a cohesive and functional environment.

### **d standards specific to Rwanda.**

## **3.7 Structural Design**

### **3.7.1 Load Calculations**

Dead Loads: Calculation of the weight of the building components, which includes the structural elements, finishes, and fixed equipment

$$dead\ load = 1.4 \cdot GK$$

Live Loads: The loads that result from occupancy, furniture, equipment, and dynamic forces. Live load =  $1.6 \cdot imposed\ load\ from\ table\ 1\ of\ BS\ 6399:1\ 1996$

wind Loads: Calculate the effects of wind, seismic action, and other environmental factors on the structure wind load =  $1.4 \cdot WK$

### **Design Codes and Standards**

International Standards: The design shall be done in accordance with international design codes, such as Euro code or ACI, for safety and reliability.

Local Regulations: The design shall adhere to local building codes and

### **Structural Analysis**

Software Tools: ArchiCAD shall be the used software tools to model and analyze the building's structural elements.

Run finite element analysis to determine the stress distribution, deformation, and stability in response to various load conditions. Manual

Calculations: The results should be checked against manual calculations for critical elements.

### **3.7.2 Design of foundation**

Foundations: Detailed design of the foundation system with respect to soil conditions, bearing capacity, and appropriate load transfer mechanisms

classification of the foundation

Shallow foundation: is the foundation where:  $df/B \leq 2.0$  where

$$df = \text{depth of the foundation}$$

$B$  =base of the foundation/footing

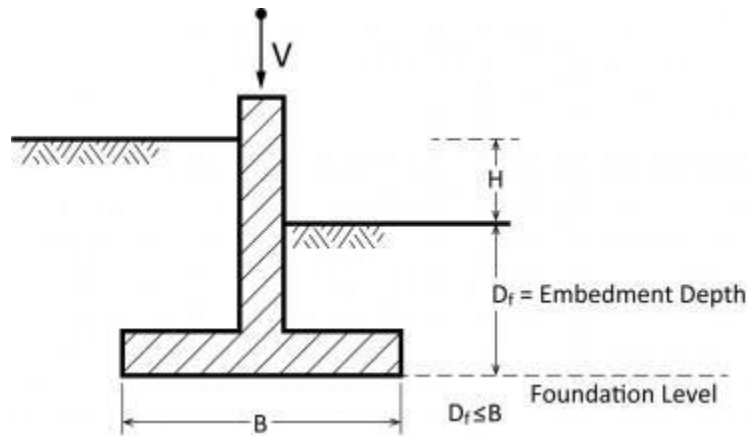

Figure 3.2: Deep foundation

Deep foundation: is the foundation where by  $d_f/B > 2$

Ex pile foundation

### Load calculation of foundation

Characteristic dead load =by considering the load from the column

Characteristic live load =by considering the load from the column

Characteristic load on foundation

$w=5\%-10\%$  of the total characteristic load from the column

$$\text{total load on the foundation} = 1.0Gk + 1.0Qk + w$$

$$\text{Area of foundation} = (\text{total load on foundation}) /$$

(bearing capacity of the soil)

Bearing capacity of the soil is the ability of the soil to withstand upper applied load.

Bearing capacity of the soil  $\neq$  Maximum pressure

Bearing capacity of the soil is determined using different method among those methods we have dynamic cone penetrometer test

Size of footing; for square footing, the size of footing is calculated  $\sqrt{(\text{Area of the footing})}$

For rectangular footing the size of footing is obtained by dividing the assumed side into the area of footing.

*If the design stress > Bearing Capacity, the footing is unsafe*

*If the design stress < Bearing Capacity, the footing is safe*

If the foundation is unsafe different decisions may be taken

- Consider the depth where bearing capacity is maximum
- Soil stabilization
- Resizing footing

$$Q \leq 0.54 \cdot R_b \cdot a_f \cdot t$$

$Q = p \cdot a_f \cdot s$ ,  $t =$  depth of the footing

$p =$  pressure/design stress

Punching shear checks

$$Q_f = N_f - \Delta q \leq R_b \cdot A_b,$$

where  $N_f =$  design load

$$\Delta q = p \cdot (ac + 2t)(bc + 2t)$$

Where  $\mu m =$  is the perimeter

$$\mu m = 2(ac + bc + 2t)$$

$Q > R_b \cdot A_b$ , the foundation is not safe with respect to punching shear.

Conclusion the thickness of the footing should be increased

Moment

$$M_{max} = (P \cdot a_f / 2) \cdot ((b_f - b_c) / 2)^2$$

Spacing of bar

$spacing = (b - 2c_{ove} - n\phi_{main\ bar}) / (n - 1)$  where  $b =$  width of foundation

$n =$  number of steel bars

Eccentrically loaded pad foundation

$$e = (M + h) / (P + w) \text{ where } e = \text{eccentricity}$$

$M + h =$  moment on the foundation

$P + w =$  load on the column

Condition :  $L/6 > e$ , where  $L =$  size of foundation

$P_{max} = (P + w) / A + (M + h) / Z >$  bearing capacity

Where  $A =$  Area

$$Z = \text{sectional modulus} = bL^2/6$$

Condition,  $P_{max} >$  bearing capacity of the soil

$$P_{min} = (P + w) / A - (M + h) / Z < 0 \text{ KN/m}^2$$

### 3.7.3. Design column

Columns and Beams: Determine the size and spacing and reinforcement details for columns and beams, respectively, for adequate strength and stiffness.

They are two type of column

- short column
- Slender column

Short column is when  $l_{ex}/h$  and  $l_{ey}/b$  is less than 15 for braced columns and less than 10 for unbraced columns.

$l_{ex}$ = effective height with respect to major axis

$l_{ey}$ = effective height with respect to manor axis

$h$ = width of column

$b$ = breadth of column

$l_e = B l_0$ , where  $n$ = coefficient that depend on end condition ( $0,75 < B < 1$ )

Table 19 and 3.20 shows the value of B for braced column and unbraced column respectively in order to control cracking in the in the column B should be depend

$N/(b \cdot h \cdot f_{cu})$  this value is found in table 3.22 of the code

Minimum reinforcement

$$A_{smin} = 0.4 \cdot A_c$$

Maximum reinforcement

$$A_{smax} = (6 \times A_c)/100$$

Link

- The diameter of link should not be less than 6mm or a quarter of maximum diameter of main bars
- The spacing of links should not be greater than 12time the maximum diameter of main bar

Design of short column

Design of short column subjected to axial lord  $N = 0.45 f_{cu} A_c + 0.95 f_y A_{sc}$

Design of short column subjected to axial load moment on one axis

$$\text{on } y \text{ axis} = N/bh$$

$$\text{on } x \text{ axis} = M/bh\epsilon$$

$$100 A_{sc}/bh = \text{the value from chart}$$

$$d = \text{cover} - (\phi \text{main bar})/2$$

Moment

$M_x/h' > M_y/b'$  The increase moment is  $M_x$

$$M_x = m_x + \beta h' / (b' m_y)$$

If  $M_x/h' > M_y/(h' M_y) = M_y + \beta b' / h' M_x$

$$M_y = m_y + B + b' / (h' m M_x)$$

The increase moment is

$$M_x = m_x + \beta \cdot h' / (b' M_y)$$

$\beta$  is coefficient which is dependent on  $N/bhfcu$  from the table 3.22

Load calculation

Requirement:

- Influence area
- Beam length
- Wall length
- Wall height = Height of column – Height of beam
- Height of the wall finishes = height of the column – Thickness of the slab

Calculation load

Dead loads

- Self-weight of the column =  $1.4 \times \text{width of the column} \times \text{breadth of column} \times \text{height of the column} \times \text{weight of concret}$
- Load from slab =  $\text{Design load of slab per unit area} \times \text{influence area}$
- Load from beam =  $1.4 \times \text{Breadth of Beam} \times \text{Thickness of Beam} \times \text{Length of Beam} \times \text{Unit of Concret}$
- Load from wall masonry =  $1.4 \times \text{width of wall} \times \text{height of wall} \times \text{wall length} \times \text{Unit weight of masonry}$
- Load from wall finishes =  $1.4 \times \text{thickness of wall finishes} \times \text{height of wall} \times \text{wall length} \times 2 \times \text{unit weight of finishes}$
- Live load =  $1.6 \times \text{live load from the table 1 of bs 6399} \times \text{influence area}$
- Load on column of ground floor

$$N_1 = (\text{load from slab} + \text{load from beam} + \text{load from wall finishes} + \text{live load}) \\ \times n^\circ \text{ of storeys} + (\text{self - weight of the column}) \times n^\circ \text{ of floor} \\ + \text{load from roof}$$



- Load from roof = *load from beam + load from slab + live load*
- Load on column of first floor

$$N_2 = (\text{load from slab} + \text{load from beam} + \text{load from wall finishes} + \text{live load}) \\ \times n^\circ \text{ of storeys} - 1 + (\text{self-weight of the column}) \times n^\circ \text{ of floor} - 1 \\ + \text{load from the roof}$$

- Load on column of last floor
- $N_3 = \text{self-weight of the column} + \text{load from the roof}$

Calculate fixed end moment of column

$$K_{AB} = 1/2 \times (bh^3)/12LaB$$

$$K_{BC} = 1/2 \times (bh^3)/12LBC$$

$$K_{BD} = K_{col} = (bh^3)/12LBD$$

$$\varepsilon K = K_{AB} + K_{BC} + K_{col}$$

$$\text{Distribution factor} = k_{col}/\varepsilon K$$

Fixed end moment at point B

$$FEM_{BA} = (ql^2)/12$$

$$FEM_{BC} = (ql^2)/12$$

$$\text{Different of moment} = FEM_{BA} - FEM_{BC}$$

$$\text{Design moment} = \text{Different of moment} \times \text{Distribution factor}$$

$$\text{If } M_x/h' \geq M_y/b'$$

The increase moment

$$M_x = M_x + \beta h'/(b' M_y)$$

$$M_x/h' < M_y/b'; M_y = M_y + \beta b'/(h' M_x)$$

$$\text{If } M_x/h' < M_y/b'$$

The increase moment

$$M_y' = M_y + \beta b'/(h' M_x)$$

$$N/bhfcu$$

### 3.7.4 Design of beam

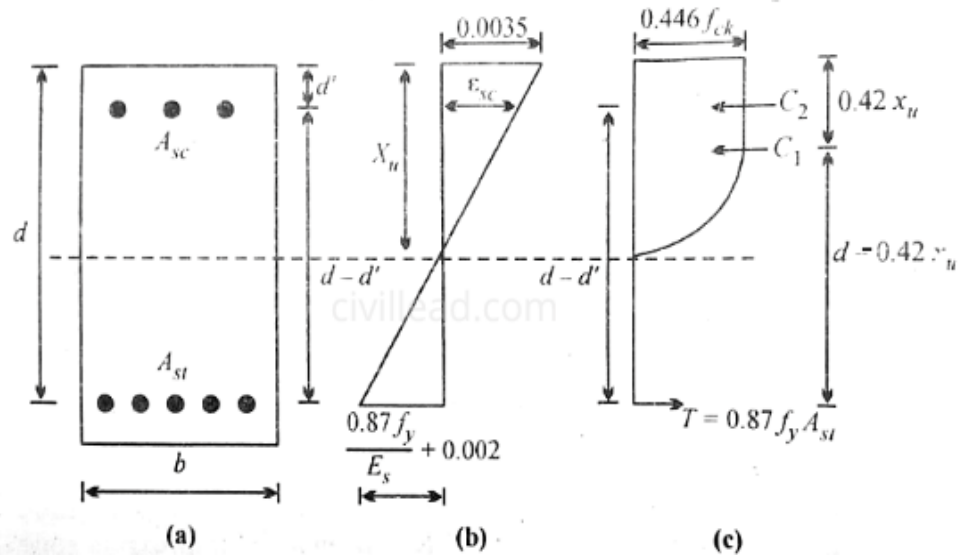

Figure 3.3 : Doubly reinforced beam

Condition:  $M_u > M_{RC}$  ;  $K > K_{Col}$

Flange beams: T beam

: L beam

T beam

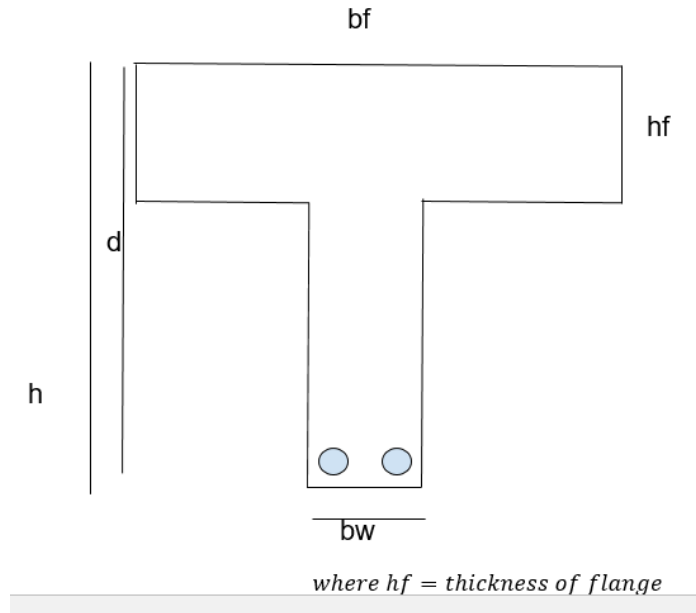

Figure 3.4: T Beam

L beam

The intention /main goal of designing beam section is to find out the area of steel needed condition

$$A_{smin} < A_s < A_{smax}$$

Where  $A_s$  = Area of steel

$A_{smin}$  = Area of steel minimum

$A_{smax}$  = Area of steel maximum

Table 3.1: Percentages of area of steel minimum

	percentage	Minimum 230N/mm <sup>2</sup>	maximum 460N/mm <sup>2</sup>
Tension r/f rectangular beam	$\frac{100A_s}{A_c}$	0.24	0.13
Flange beam web in Tension			
$\frac{bw}{b} < 0.4$	100AS/bwh	0.32	0.18
$\frac{bw}{b} \geq 0.4$	100AS/bwh	0.24	0.13
compression r/f rectangular Beam	100Asc/Ac	0.2	0.2
Flange beam web in compression	100ASc/bwhf	0.2	0.2

Where  $A_s = \text{Area of tension}$

$A_{sc} = \text{Area compression}$

$A_c = \text{Area of concrete section} = bh$

$r/f = \text{reinforcement}$

$A_{smax}$  should not be greater than 4%

### Moment of resistance

Calculation of internal forces

$$force = J \times A$$

$$C = 0.201 bd f_{cu}$$

$$T = 0.95 f_y \times A_s$$

For equilibrium internal forces should be equal

$$c = T$$

$$A_s = (0.211 \cdot bd \cdot f_{cu}) / f_y$$

$$Z = 0.775d$$

Z=lever arm

Moment of resistance of steel

$$MRC = T \times Z = 0.95fyAs = 0.736dfyAs$$

Moment of resistance of concrete.

$$M = c \times Z = 0.201fcubd \times 0.775d$$

$$MRC = 0.156fcubd^2$$

For equilibrium

$$MRS = MRC$$

$$0.736dfyAs = 0.156fcubd^2$$

$$AS = MRC/0.736dfy \Rightarrow 0.212 fcubd/fy$$

Percentage of reinforcement

$$p = 100As/bd$$

$$MRC = 0.156fcubd^2$$

$$K = MRC/(fcubd^2) \text{ where } k \text{ is the factor ractor}$$

$$Kbal = 0.156$$

If  $MU < MRC$ , no compression bar required

$MU >$ , compression bars required

Where  $Mu$ =ultimate moment bars required

$MRC$ =moment of resistance of the concrete

Or

If  $K < Kbal$ , no compression bar required

$K > Kbal$ , compression bar required

$$Z = d[0.5 + \sqrt{(0.25 - k/0.9)}] \geq 0.95d$$

If  $Z > 0.95$ ; take  $Z = 0.95d$

$$As = MRC/0.95fyZ \Rightarrow Asmin = 0.13AC/100 \Rightarrow Ac = bh$$

$$Asmax = (4 \times Ac)/100 \Rightarrow (4 \times bd)/100$$

$$Asmin \leq As \leq Asmax$$

Calculated area of steel  $As = MRC/0.95fyZ$  is called area of steel required  $\Leftrightarrow As \text{ reg} = MRC/0.95fyZ$

As provided = AS provided is found in the table of groups of bars.

As provided: it is the area which is greater than as required but which is very close to it

As provided gives us number and size of steel bar and sometime spacing of bars

$$K = MRC / (fcubd^2)$$

For doubly reinforced beam concrete beam

For internal equilibrium

$$T = Cs + Cc \Rightarrow Cc = 0.45fcu \times 0.9x \times b \\ = 0.203fcubd$$

$$Cs = \delta \times A = 0.95fy \times As$$

$$T = 0.95fyAS$$

$$AS = AS - 0.203fcubd / 0.95FY$$

$$Cs = (M - MRC) / (d - d')$$

$$Cs = 0.95fy \times As$$

$$AS' = Cs / 0.95fy \text{ replace } Cs \text{ by its value}$$

$$AS' = (M - MRC) / ((d - d') \times (0.95fy))$$

$$d' \approx 0.214d \approx 0.43x$$

Flanged beam

If  $MU < MRC$ , the neutral axis is located in flange then the beam will be designed as rectangular beam if  $Mu > MRC$ , the neutral axis is located in web. then the beam will be designed as flanged beams.

$$MRC = 0.45fcubhf(d - hf/2)$$

Neutral axis in web

Tension reinforcement only  $Mu < MRC$

$$MRC = 0.95fyAs(d - hf/2) - 0.2fcubwb(0.225d - hf/2)$$

$$As = (M + 0.1fcubwb(0.45d - hf)) / 0.95fy(d - hf/2)$$

Tension reinforcement and compression reinforcement

$$MRC = fcubd^2 [0.45 hf/d (1 - bw/b)(1 - hf/2a) + 0.155 bw/b]$$

$$As' = (M - MRC) / 0.95fy(d - d')$$

$$As = 0.2fcubwd + 0.45fcuhf(bf - bw) + AS$$

$$d'/x \approx 0.43 \Leftrightarrow d' \approx 0.43x$$

$$b = bf$$

$$bf = bw + lz/5 \text{ for T beam}$$

$$bf = bw + lz/10 \text{ for L beam}$$

$lz = \text{distance between point of zero moment (effective span)}$

For continuous beam  $lz = 0.7 \times \text{effective span}$

Shear reinforcement design

$$\text{Shear stress} = v = w = v/bd$$

$$v = \text{maximum shear force}$$

$$\text{Shear capacity} = Vc = Wc$$

$$Vc = (0.79(100As/bd) (( [1/3] ^ (400/d) ) / 4 (fcu/2s) ) / 3) / 1.25$$

$$(100As/bd) [1/3] ^ \neq 3$$

$$(400/d) ^{1/4} \neq 1$$

$$(fcu/2s) ^{1/3} \neq 1$$

If  $V < Vc$  no shear reinforcement required

If  $V > Vc$  shear reinforcement required

Deflection of beam

Deflection in a beam should be minimized the code (Bs 8110:part 2) in its clause 3.2.1 state that deflection should not be greater than  $L/250$ ; where L is effective span deflection affects finishes in order to make that deflection should not affect finished the following limits are respected

$$\frac{L}{350} \text{ for brittle finishes}$$

$$\frac{L}{500} \text{ for non-brittle finishes}$$

Span to effective depth

Basic span to effective depth ratio Basic span depends on the Beam sections rectangular beam or flanged beam the basic span/d is given in table 3.9 of the code

Table 3.2: Span to effective ratio table 3.9 of the code

Support condition	rectangular beam	Flanged beam $b_w/b \leq 0.3$
Cantiliver	7	5.6
simply supported	20	16.0

continuous	26	20.8
------------	----	------

this value is applied to span up to 10 m if you have to close out of 3.4.6.4 for long span( > 10m)

Modification factor

$$M.F = 0.55 + (477 - f_s) / 120(0.9 + M / (bd^2)) \leq 2$$

$f_s$  = services stress

$$f_s = 2/3 (f_y \times A_{s \text{ reg}}) / A_{s \text{ prouv}} \times 1/B_b$$

$$B_b = (\text{moment after redistribution}) / (\text{moment before redistribution})$$

When there is no moment redistribution.  $f_s = 2/3 f_y$  table 3.10 of the code highlights the values of

$B_b$  and in normal cases  $B_b$  is taken as 1

$A_{s \text{ req}}$  = Area of steel required at mid span to support ultimate loads

$A_{s \text{ prouv}}$  = Area of steel provided at midspan

Compression reinforcement

$$M.F = 1 + ((100A_{s' \text{ prouv}}) / bd) / (3 + (100A_{s' \text{ prouv}}) / bd) \leq 1.5$$

Allowable span to effective depth ratio

Basic span to effective depth ratio  $\times M.F$  for tension reinforcement  $\times M.F$  for compression rf

$$\text{Actual span to effective depth ratio} = (\text{effective span}) / d = \text{span} / d$$

If allowable span to effective depth ratio is greater than actual span to effective depth ratio the beam is satisfactory with respect to deflections

if allowable span/d is less than actual span/d beam is not satisfactory with respect to deflection

### 3.7.5 Design of slab

Slab is horizontal flat structure elements that is provided as a cover of floor of the building, slab support different loads such as its self-weight and imposed load

Type of slab

One-way slab = slab spanning in one direction

Two-way slab = slab spanning in two direction

Flat slab is a slab which is supported by columns and beam without intermediate beam

Condition

If  $(l_y) / l_x \leq 2$  the slab is a two way slab

If  $l_y / l_x > 2$  the slab is a one way slab

Where  $l_y$  is long span



$l_x$  is short span

The thickness of slab is ranging between

$$l_x/20 \text{ and } l_y/40$$

Calculation loads

Dead load calculation.

Self-weight of the slab = thickness of the slab \* unit weight of concrete \* breadth of slab ( $b=1\text{m}$ )

Finishes =  $1.4$  \* unit weight of finishes \* breadth of slab

Total = self-weight of the slab + finishes

Imposed load calculation

imposed load/live load =  $1.6$  \* imposed load from table 1 of BS 6399:1-1996

design load = design dead load + design live load

calculation of moment

$$M_{sx} = B_{sx} * n * (l_x)^2$$

$M_{sy} = B_{sy} * n * (l_y)^2$  where  $B_{sx}$  and  $B_{sy}$  are moment coefficient from table 3.14 of the code (BS 8110:1-1997) these coefficients depend on the type of panel and value of panel and value of  $l_y/l_x$

$n$  = design load

### 3.7.6 Design of Stair and Ramps

A stair is composed with landing and steps, where step = riser and going

Number of rises = number of going + 1

Slope relationship  $550 < 2R + G < 700$

dead load calculation out of landing

self-weight =  $1.4$  \* thickness of stair slabs \* length of flight \* width of flight \* unit weight of concrete.

Imposed load =  $1.6$  \* length of flight \* width of flight \* imposed load from table

Landing

Self-weight of landing =  $1.4$  \* width of landing \* length of landing \* thickness of landing

Total design load = self-weight of landing + imposed load

Design and Formwork: Detailed design of staircases and ramps includes rise and tread dimensions.

Formwork is set up to shape the stairs and ramps.

Reinforcement: Reinforcing steel is laid in the formwork; with required overlaps and anchorage at landings.

Concrete Pouring: Concrete is poured in steps and compacted. Finishing consists of troweling to provide a smooth surface and non-slip treatments where necessary.

Curing: Adequate curing is necessary to prevent cracking and achieve the strength needed.

Electrical and Plumbing Installations: Conduits and pipes shall be embedded in walls and slabs. Connections shall be made according to safety standards and design specifications.

## CHAPTER 4.RESULTS AND DISCUSSIONS

### 4.0 Introduction

This chapter presents the results obtained from the structural design and analysis of the Nyabugogo Station redevelopment project. The outcomes of the geotechnical analysis, material selection, structural load analysis, and design decisions are discussed in detail. Furthermore, the challenges posed by the swampy site conditions and the methods implemented to overcome these obstacles will be examined in the context of the overall design's effectiveness, compliance with standards, and durability.

### 4.1 Design of slab

For calculating the design of slab, we need to choose the critical panel.

The critical panel is the panel that are supposed to carry the biggest load and who has the biggest  $L_y$  and  $L_x$  where  $L_y$  is the long span and  $L_s$  is the short one. we can know that the panel are carried the biggest load if it loaded not from a stair.

Let consider that the critical panel is the panel 294

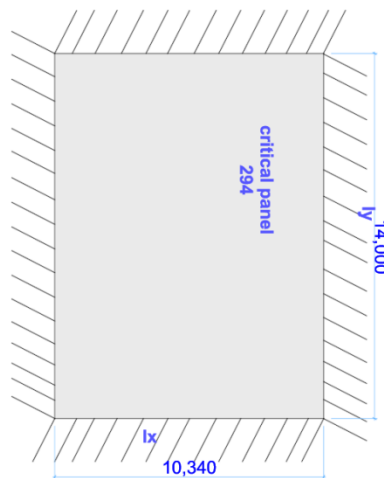

Figure 4.1: Slab Panel

$$L_x = 1400$$

$$L_y = 1034$$

By consider the two types of slab to determine the types of slab.

If  $\frac{L_y}{L_x} \leq 2$  the slab is two ways slab

If  $\frac{L_y}{L_x} > 2$  the slab is a one-way slab

$$\frac{Ly}{Lx} = \frac{1400}{1034} = 1.35 \text{ the slab is 2 ways slab}$$

The thickness of slab is ranging between

$$\frac{Lx}{20} \text{ and } \frac{Lx}{40} n *$$

$$\Rightarrow \frac{Lx}{20} = 70 \text{ Cm}$$

$$\Rightarrow \frac{Lx}{40} = 25.85 \text{ Cm}$$

By considering that the thickness of slab is given as 25 Cm

### Calculation load:

Self-weight of the slab = Thickness of slab \* Unit Weight of concrete \* 1.4 \* Breadth of slab (b= 1m)

$$= 0.25 * 1.4 * 25 * 1 = 8.75 \text{ kN/m}$$

Finishes load = 1.4 \* Unit weight of finishes \* Breadth of slab

$$= 1.4 * 19 * 1 = 26.6 \text{ kN/m}^2$$

Total = self-weight \* Finishes = 8.75 + 26.6 = 35.35 kNm<sup>3</sup>

Imposed load

Live load = 16 \* Imposed load from the table 1 of BS 6399:1996

We assume that, Imposed load from table = 3 kN/m<sup>2</sup>

$$= 1.6 * 3 = 4.8 \text{ kN}$$

Calculation moments:

$$MSx^- = BSx * (Lx)^2 = MSy^- \Rightarrow BSy * n * (Ly)^2$$

$$MSx^+ = BSx * n * (Lx)^2 \Rightarrow MSy^+ = BSy * n * (Ly)^2$$

Where BSx and BSy are moment coefficient from table 3.14 of the code (BS \* 110:1 – 1997)

The coefficient depends on the type of panel and value of  $\frac{Ly}{Lx} = 1.35 \approx 1.4$

n = design load

$$MSx^- = 0.0500 * 57.17 * (10.34)^2 = 305.662 \text{ kNm}$$

$$MSy^+ = 0.037 * 57.17 * (10.34)^2 = 226.145 \text{ kNm}$$

$$MSy^- = 0.032 * 57.17 * (14)^2 = 358.57 \text{ kNm}$$

$$MSy^+ = 0.024 * 57.17 * (14)^2 = 268.927 \text{ kNm}$$

Shear Force

$$\frac{L_y}{L_x} = 1.35 \approx 1.4$$

$$V_{Sx} = B_{Xx} * n * L_x = 0.43 * 57.17 * (10.34) = 254.18$$

$$V_{Sy} = B_{Xy} * n * L_y = 0.33 * 57.17 * (14) = 254.12$$

### Design for moments

$$MRC = 0.156$$

$$d = h - cover - \frac{\phi \text{ main bar}}{2}$$

Let assume that  $\phi$  main bar 16 mm

$$d = h - cover - \frac{\phi \text{ main bar}}{2}$$

$$h = 250 - 25 - \frac{16}{2} = 217 \text{ mm}$$

$$MRC = 0.156 * 30 * 1000 * (217)^2$$

$$= 220.376520$$

$$M < MRC$$

$$57.17 < 220.376520 \Rightarrow \text{No compression}$$

Bar required:

$$k = \frac{M}{f_w b d^2} = \frac{57.17 * 10^6}{30 * 1000 * (217)^2} = \frac{57170000}{6310000} = 0.040$$

$$k < k_{bal} \quad 0.028 < 0.156 \Rightarrow \text{No compression}$$

$$Z = d \left[ 0.5 + \sqrt{0.25 - \frac{15}{0.9}} \right]$$

$$Z = 217 \left[ 0.5 + \sqrt{0.25 - \frac{0.04}{0.9}} \right]$$

$$Z = 217 [0.5 + \sqrt{0.25 - 0.044}]$$

$$Z = 217 [0.5 + \sqrt{0.206}]$$

$$Z = 217 [0.5 + 0.45]$$

$$Z = 206.99 \approx 0.957217$$

$$Z = 206.99 \approx 206.13$$

Let take  $Z = 206.15$

$$A_{sreq} = \frac{M}{0.95f_y Z} = \frac{57.17 * 10^2}{0.95 * 460 * 206.15} = \frac{57170000}{9008755} = 634.6 \approx 635$$

$$A_{sprov} = 678 \text{ 6T12}$$

$$A_{smin} = \frac{4 * AC}{100} = \frac{0.13 * B * h}{100} = \frac{0.13 * 1000 * 250}{100} = 325$$

$$A_{smax} = \frac{4 * AC}{100} = \frac{4 * b * h}{100} = \frac{4 * 1000 * 250}{100} = 10000$$

The condition is verified

$$A_{smin} < A_s < A_{smax} \Rightarrow 325 < 635 < 10000$$

### Design for shear

Shear at point x  $V=254.18$

$$W = V = \frac{V}{bd} = \frac{254.18 * 10^3}{1000 * 217} = \frac{254180}{217000}$$

$$V = 1.17 \text{ N/mm}^2$$

$$V_c = W_c = \frac{0.79 \left( \frac{100A_s P}{bd} \right)^{1/3} \left( \frac{400}{d} \right)^{1/4} \left( \frac{f_w}{25} \right)^{1/3}}{1.25}$$

$$\left( \frac{100A_s P}{bd} \right)^{1/3} \Rightarrow \left( \frac{100 * 678}{1000 * (217)} \right)^{1/3}$$

$$\left( \frac{67800}{217000} \right)^{0.333} = 0.68123$$

$$\left( \frac{400}{d} \right)^{1/4} \Leftrightarrow \left( \frac{400}{217} \right)^{0.25} = 1.16 > 10k$$

$$\left( \frac{f_w}{25} \right)^{1/5} \Leftarrow 1 \left( \frac{30}{25} \right)^{1/3} = 1.06 > 10k$$

$$V_c = \frac{0.79 * 0.681 * 1.16 * 1.06}{1.25} = 0.49 \frac{N}{\text{mm}^2}$$

$$V < V_c; \frac{1.17N}{\text{mm}^2} > \frac{0.49N}{\text{mm}^2}$$

Shear reinforcement is required

### Deflection check

Basic span to effective depth ratio from table 3.9 of the code basic span /d =26 for continuous slabs.

M.F for tension reinforcement

$$MF = 0.55 + \frac{477 - fs}{120(0.9 + \frac{M}{bd^2})} \leq 2.0$$

$$fs = \frac{2}{3} fy * \frac{Asreq}{Asprov} * \frac{1}{Bb}$$

$$fs = \frac{2}{3} * 460 * \frac{635}{678} * 1 = \frac{287.21N}{mm^2}$$

$$\frac{M}{bd^2} = 0.53 + \frac{477 - 287.21}{120(0.9 + 121)}$$

$$= 0.55 + \frac{189.7826941987}{253.6900762386}$$

$$= 1.36 + 0.55 = 1.91 < 2$$

Allowable span/d = basic span/d \* MF

$$= 26 * 1.91 = 49.66$$

$$\text{Actual span/d} = \frac{10340mm}{217mm} = 47.6$$

Allowable span/d > actual span/d the slab is satisfactory with respect to deflection.

### Crack control

Spacing between bars should not be greater than 3d where d is effective depth 3d = 3 \* 217 = 651mm

As calculated (consider spacing (160mm) is less than 3d = (651) there is no cracking.

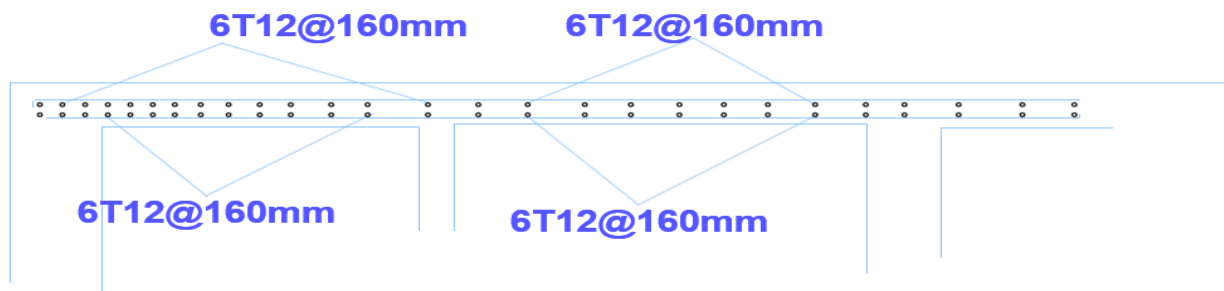

Figure 4.2: Slab reinforcement

### 4.2 Design of beam

For designing a beam, we need to follow this step

- Beam section
- Load on beam
- B.M and shear F

-Area of steel

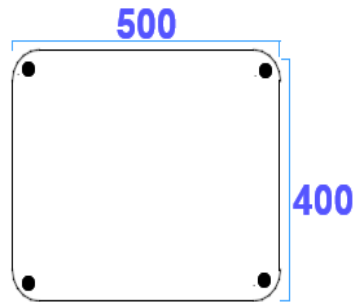

Figure 4.3: Reinforcement of beam

The intention / main goal of designing beam section is to find out the area of steel needed condition

$AS_{min} < AS < AS_{max}$

Where AS=Area of Steel

AS min = Area of steel minimum

AS max = Area of steel maximum

By considering the predesign we will start on it, thickness or depth of beam  $\frac{l_{max}}{12} \leq \frac{l_{max}}{8}$  where  $l_{max}$  =maximum span =1400

By knowing that our beam size is equal to 40\*50cm breath of beam  $h/3 \leq h/2 \Rightarrow \frac{500}{3} \leq \frac{500}{2} 166.66$

$\leq 250$  load distribution from two-way slab to the beam

total self-weight of slab = w  $\Rightarrow l_x$  shorter side of the slab

distribution of two-way slab for triangular load = w \*  $\frac{l_x}{3}$  self weight of the beam

beam size= 40\*50cm

load on the span

fixed end moment for triangular section  $\frac{0.25l_x}{l_y - 0.5l_x}$

for trapezoidal load  $w = w * \frac{l_x}{x} (1 - \frac{1}{20})$

$p_1 = \frac{wl_x}{3} (\frac{3-m}{2})$  where  $m = \frac{l_x}{l_y}$

fixed end moment for trapezoidal load

$$\frac{l_y - l_x}{l_y - 0,5 l_x} * w$$



$M = \frac{wl}{8}$  where  $w$  = design load from slab

$$M = \frac{57.17 * (1400)}{8}$$

$D$  = effective depth  $\Rightarrow d = \text{cover} - h - \frac{\phi_{main\ bar}}{2} \phi_{link}$

$$d = 500 - 25 - \frac{16}{2} - 8 = 459$$

$B_f = b = 400$

$H_f$  = thickness let us take 116mm

$$MRC = 0,45 * f_{cu} * b * h_f \left( d - \frac{h_f}{2} \right)$$

$$MRC = 0,45 * 25 * 400 * 116 \left( 459 - \frac{116}{2} \right)$$

$$MRC = 13896,684000 \text{ N/mm}$$

$$M < MRC \Rightarrow 307699.62 < 138699.62$$

$$K = \frac{MRC}{f_{cu} b d^2} = 0,065$$

$$k > k_{bal}, 0,065 > 0,156$$

$$z = d \left[ 0,5 + \sqrt{0,25 - \frac{k}{0,9}} \right] = 459 \left[ 0,5 + \sqrt{0,25 - \frac{0,065}{0,9}} \right]$$

$$z = 423,15 \approx 0,95d \Rightarrow 0,95 * 459$$

$$423,15 > 436.05$$

Let us take  $Z = 423.15$

$$A_s = \frac{MRC}{0,95 f_y z} = \frac{13896684}{0,95 * 460 * 423,15} = 751,51$$

$$A_{sreq} = 751,51$$

$$A_{sprov} = 791 \text{ mm}^2 \text{ 7T12}$$

$$A_{smin} = \frac{0,13 * A_c}{100} = \frac{0,13 * 400 * 116}{100} = 603$$

$$A_{smax} = \frac{4 * A_c}{100} = \frac{4 * 400 * 116}{100} = 1856$$

Figure 4.4: Reinforcement bars of beam

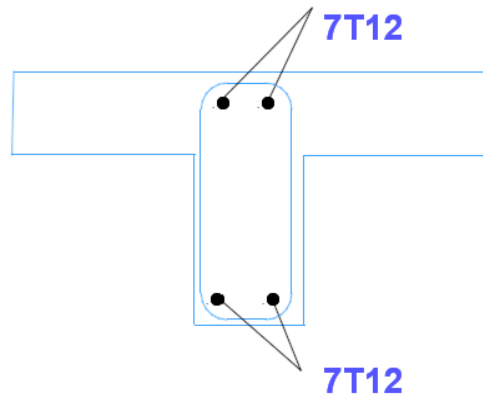

$A_{smin} < A_s < A_{smax}$  the condition is already proved

### 4.3.Design of column

We will calculate total level on the column from the given structural by knowing the size of column = 50\*50

Thickness of beam = 50mm

Design load of beam = 57.17 KN

Live load = 3kN from the table

Weight of concrete = 25 kN/m<sup>2</sup>

Height of column = 4m

Calculation of loads

Dead loads\*self – weight of the column = 14\*width of column\*breadth of column\*height of column weight of concrete = 1.4\*0.5\*4\*0.5\*25 = 35 KN

Panel A= length\*width

Influence area = A1+A2+A3+A4

$$A1 = 3 * 2.87 = 8.61 \text{ m}^2$$

$$A2 = 3 * 7 = 21 \text{ m}^2$$

$$A3 = 2.17 * 2.87 = 6.22 \text{ m}^2$$

$$A4 = 2.17 * 7 = 15.19 \text{ m}^2$$

$$\begin{aligned} \text{Influence area} &= 8.61 + 21 + 6.22 + 15.19 \\ &= 51.02 \text{ m}^2 \end{aligned}$$

$$\text{Beam length} = (2.17 + 3) (7 + 2.87) - 0.5 = 14.54$$

$$\begin{aligned} \text{Wall length} &= (2.17 + 3) - 0.5 + (7 + 2.87) - 0.5 \\ &= 4.67 + 9.37 = 14.04 \text{ m} \end{aligned}$$

Wall height = height of column – Height of beam = 4 - 0.5 = 3.5m

Height of wall finishes = Height of column thickness of slab = 4 – 0.25 = 3.75

### Calculation of loads

Dead loads\*Self – weight of the column = 1.4 \* width of column\*breath of column\*Height of column weight of concrete =  $1.4*0.5*0.5*4*24 \text{ kN/m}^3 = 33.6 \text{ KN}$

Load from slab = Design load of slab per unit area\*influence area =  $57.17*51.62 = 2916.8134$

Load from beam = 1.4\*breadth of beam\*Thickness of beam\*Beam Length\*Unit of Concrete

Consider

Breadth of beam = 40Cm

$$=1.4*0.4*0.5*3*24 = 20.16$$

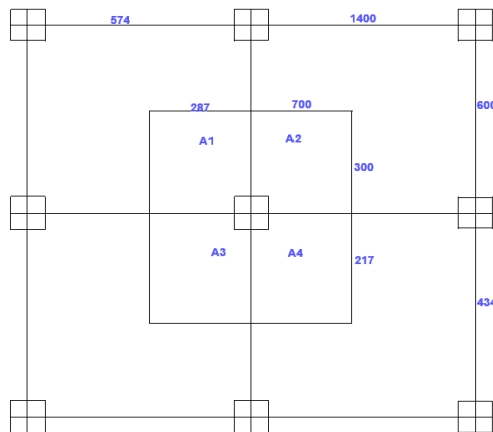

Figure 4.5: Influence area

Load from wall masonry = 1.4\*Width of wall\*Height of wall\*Wall length\*unit weight of masonry.

Width of wall = 20 Cm

$$= 1.4*0.2*3.5*19 = 111.72 \text{ KN}$$

Load from finishes = 1.4\*Thickness of finishes\*height of wall\*length of wall\*2\*Unit weight of finishes = 3

$$= 14*0.03\text{m}*3.5*6*2 = 33.516 \text{ KN}$$

Live load = 1.6 live load from table 1 of BS 6399\*influence area

$$=1.6*3*51.02 = 244.896$$

Load on column of ground floor

$$N1 = (2919.81 + 20.16 + 111.72 + 33.51 + 244.896) * 3 + (33.6) * 4 = 16489.74 + 134.4 + 5384.86$$

$$\text{Load from roof} = 2919.81 + 20.16 + 244.89 = 3184.86$$

$$N1 = 12.873.84 \text{ kN}$$

$$N2 = (2919.81 + 20.16 + 111.72 + 33.51 + 244.896) * 2 + (33.6) * 3 + 3184.86 = 6660.18 + 3285.66 = 9945.84 \text{ kN}$$

$$N3 = (2919.81 + 20.16 + 111.72 + 33.51 + 244.896) * 1 + (33.6) * 2 + 3184.86 = 3330.09 + 3252.06 = 6582.15 \text{ kN}$$

$$N4 = (33.6) * 1 + 3184.86 = 3218.46 \text{ kN}$$

Calculate fixed end moment for the column which is subjected to axial load and biaxial load bending moment consider the size beam = 40 Cm

Height of column = 4m characteristic dead load

Consider dead load from column = 33.6

Consider live load from column = 244.896

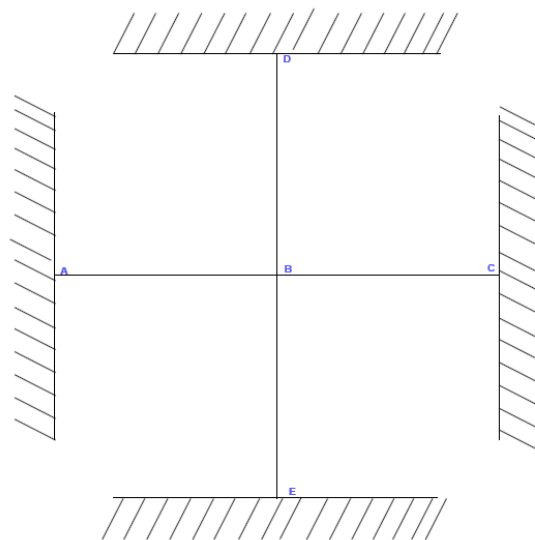

Figure 4.6: Direction of column

$$\begin{aligned} K_{AB} &= \frac{1}{2} * \frac{bh^3}{12LaB} = \frac{1}{2} * \frac{0.4 * (0.5)^3}{12 * 600} \\ &= 0.5 * \frac{0.4 * 0.25}{72} = 0.5 * \frac{0.1}{72} = 0.5 * 0.00138 \\ &= 0.000694 \approx 694 * 10^{-6} \end{aligned}$$

$$KBC = \frac{1}{2} * \frac{bh^3}{12LBC} = \frac{1}{2} * \frac{0.4*(0.5)^3}{12*4.34}$$

$$= 0.5 * \frac{0.1}{12*4.34} = 0.5 * \frac{0.1}{52.08}$$

$$KBD = Kcd = \frac{bh^3}{12LBD} = \frac{(0.4)^4}{12*1.4} = \frac{0.0256}{16.8} = 0.00015 \approx 15 * 10^{-5}$$

$$\varepsilon k = KAB + KBC + Kcd$$

$$= 0.000694 + 0.00096 + 0.00015 = 0.001804 \approx 1804 * 10^{-6}$$

$$\text{Distribution factor} = \frac{Kcd}{\varepsilon k} = \frac{0.00015}{0.001804} = 0.0831$$

Fixed end moment at point B

$$FEMBA = \frac{qL^2}{12} = \frac{(14*33.6)+(1.6*244.8)(6)^2}{12}$$

$$= \frac{47.04+391.68}{12} * 36$$

$$= \frac{15791.04}{12} = 1315.92 \text{ kNm}$$

$$FEMBE = \frac{qL^2}{12} = \frac{33.6*(4.34)^2}{12} = 52.739$$

Difference of moments = FEMBA – FEMBC

$$1315.92 - 52.739 = 1263.19$$

Design moment = difference of moment\*distribution factor = 1263.19\*0.0831 = 104.971kNm

my = 104.971 kNm

$$KAB = \frac{1}{2} * \frac{bh^3}{12 * LAB} = \frac{1}{2} * \frac{0.4 * (0.5)^3}{12 * 5.74} = 0.5 * \frac{0.05}{68.88} = 0.00072 * 0.5 = 0.00036$$

$$KBC = \frac{1}{2} * \frac{bh^3}{12 * LBC} = \frac{1}{2} * \frac{0.4 * (0.5)^3}{12 * 14} = 0.5 * \frac{0.05}{168}$$

$$KBD = Kcd = \frac{bh^3}{12 * LBB} = \frac{(0.4)^4}{12 * 4} = \frac{0.0256}{48} = 0.00053$$

$$\varepsilon k = KAB + KBC + Kcd = 0.00036 + 0.00014 + 0.00053 = 0.00103$$

$$\text{Distribution factor } k = \frac{Kcd}{\varepsilon k} = \frac{0.00053}{0.00103} = 0.514$$

Fixed end moment at point B

$$FEMBA = \frac{qL^2}{12} \text{ let us assume } 14Gk + 1.6Qk$$

$$14Gk = 41.32$$

$$1.6Qk = 57.72 \text{ kN}$$

$$FEMBA = \frac{41.32 \times 3.74^2}{12} = 113.44 \text{ kN}$$

$$FEMBC = \frac{57.72 \times 14^2}{12} = 942.76 \text{ kN}$$

$$\text{Difference of moment} = 942.76 - 113.44 = 829.32$$

$$\text{Design moment} = \text{Difference of moment} * \text{Distribution factor} = 829.32 * 0.514 = 426.27 \text{ kN}$$

$$M_x = 426.27$$

$$h' = h - \text{cover} - \frac{\phi_{\text{main bar}}}{2} - \phi_{\text{links}}$$

$$\text{Let us assume cover} = 25 \text{ mm}$$

$$\phi_{\text{main bar}} = 16 \text{ mm}$$

$$\phi_{\text{links}} = 8 \text{ mm}$$

$$h' = 500 \text{ mm} - 25 \text{ mm} - \frac{16 \text{ mm}}{2} - 8 \text{ mm} = 459 \text{ mm}$$

$$b' = 500 \text{ mm} - 25 \text{ mm} - \frac{16 \text{ mm}}{2} - 8 \text{ mm} = 459 \text{ mm}$$

$$\text{if } \frac{M_x}{h'} \geq \frac{M_y}{b'}$$

The increase moment

$$M_x' = M_x + B \frac{h'}{D'} M_y$$

$$\frac{M_x'}{h'} = \frac{426}{459} = 0.92$$

$$\frac{M_x}{h'} > \frac{M_y}{b'} \quad M_x = M_x + B$$

$$B = 0.53$$

$$M_x' = 426 + 0.53 * \frac{459}{459} * 104.97$$

$$M_x' = 44359.12$$

$$\text{If } \frac{M_x}{h'} < \frac{M_y}{b'}$$

The increase moment

$$M_y' = M_y + B \frac{b'}{h'} M_x$$

$$\frac{M_y}{b'} = \frac{104.97}{459} = 0.22$$

$$\frac{b'}{h'} M_y \frac{M}{b h f \omega} = \frac{12.87384 * 10}{500 * 500 * 30} = \frac{12.6734}{7500000} = 1.71$$

#### 4.4. Design of foundation /footing

Figure 4.7: Footing sides

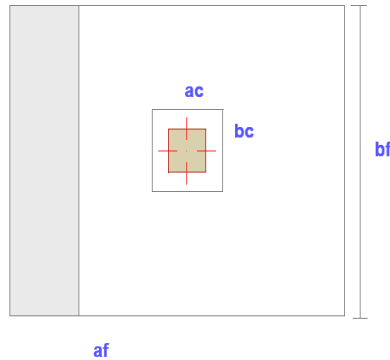

Classification of foundation

Shallow foundation: is the foundation where by  $\frac{df}{B} \leq 2D$

where:

df = depth of foundation

B = Base of foundation/footing

#### Loads calculation

Dead load = consider the load from column = 35

Live load = consider the load from column = 244

Characteristic load on foundation

$\omega = 5\% - 10\%$  of the total characteristic load from the column

Total on foundation =  $1.0 Gk + 1Qk + \omega =$  service load for column +  $\omega$

Let us say  $\omega = 10\%(10Gk + 1.0Gk)$

$$\omega = \frac{1.0 * 35 + 1.0 * 244.89 * 10}{100} = 27.989 \text{ kN}$$

16 loads on footing =  $2798.9 + 27.989 = 2826.889 \text{ kN}$

$$\text{Area of footing} = \frac{\text{load on footing}}{\text{Bearing capacity}}$$

Let us assume the bearing capacity is equal to  $350 \text{ kN/m}^2$

$$\text{Area of the footing} = \frac{2826.889 \text{ kN}}{350 \frac{\text{kN}}{\text{m}^2}} = 8.07 \text{ m}^2$$

$$\text{Square footing} = \sqrt{8.07 \text{ m}^2} = 2.84 * 2.84$$

If design stress > bearing capacity the foundation is unsafe

If design stress < bearing capacity the foundation is safe

$$\text{Consider design load} = \frac{2008}{2.84 \times 2.84} = 249.1315$$

Design stress < Bearing capacity

The foundation is safe

Let take the thickness of footing =80cm

T depth of footing

$$T = \text{thickness of footing} - \text{cover} - \frac{\phi_{\text{main bar}}}{2} \Rightarrow 80 - 5 - \frac{16}{2} = 67 \text{ cm}$$

$$P = 249.13 \text{ kn/m} = 0.024913$$

$$A_f = 150$$

$$S = 25 \text{ cm}$$

$$B_f = 150$$

$$A_c = 50$$

$$B_c = 50$$

$$0.54 R_b \cdot a_f \cdot t = 0.54 \cdot 0.09 \cdot 150 \cdot 67 = 48843$$

$$Q = P \cdot a_f \cdot s = 93.423$$

$Q < 0.54 R_b \cdot a_f \cdot t$ , the condition is verified punching shear check

Where d is effective depth of the footing

$$Q_f = n_f \cdot c$$

should be less or equal to  $R_b \cdot A_b$  where  $n_f = \text{design load}$

$$\Delta q = p \cdot (a_c + 2t) \cdot (b_c + 2t)$$

$$R_b = 0.09$$

$$A_b = u_m \cdot t$$

$$u_m = 2(a_c + b_c + 2t) = \text{perimeter}$$

Using design load of column

$$A_c = 50$$

$$B_c = 50$$

$$T = 67$$

$$P = 0.024913 \text{ KN/cm}$$

$$\Delta q = 0.024913 \cdot (50 + 2 \cdot 67) \cdot (50 + 2 \cdot 67)$$

$$N_f = 2008 \text{ KN}$$



$$Q_f = 2008 - 843.45 = 1164,55$$

$$U_m = 2(50 + 50 + 2 \cdot 67) = 468 \text{m}^2$$

$Q_f < R_b \cdot A_b$  the foundation is not safe with respect to punching shear

Conclusion: the thickness should be increased.

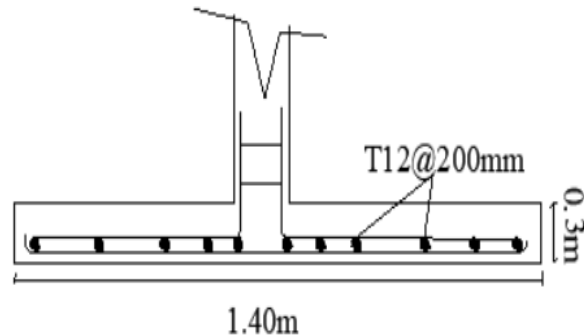

Figure 4.8: Footing reinforcements

#### 4.5. Design of stairs

Stair is composed with landing and steps: Risers and goings.

Number of risers = Number of going + 1

Slop relationships.

$$550 < 2R + G < 700$$

Numbers of riser

Size of goings

Size of riser

Size of landing

Length of going of flight

Length of flight = Slope length

Height of floor to floor =

Slope = pitch

Thickness of waist

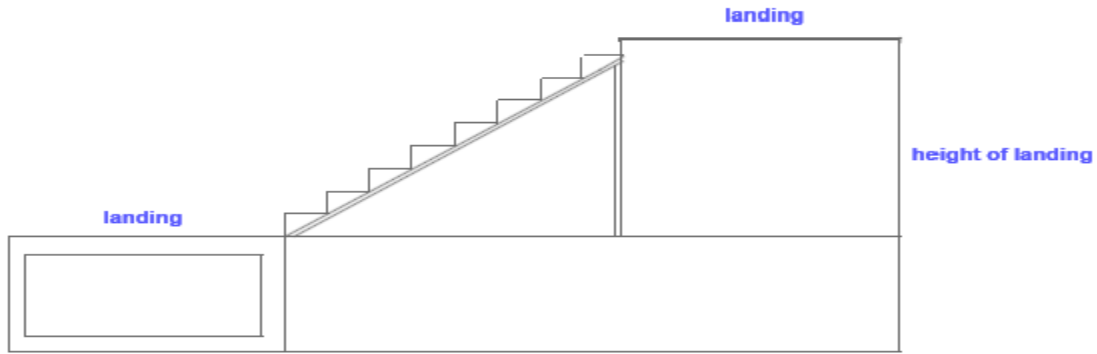

Figure 4.9: Stair sections

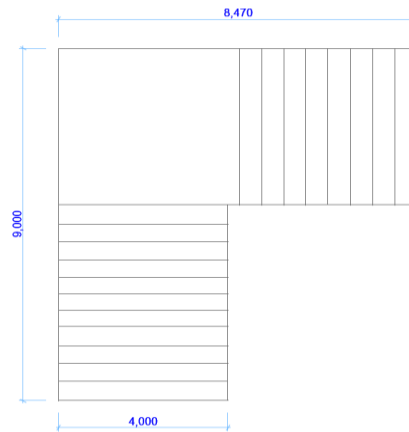

Figure 4.10: Stair measurements

### Design load

Moment

Height of floor to floor = 4m

Width of beam / width of column = 40

Numbers of going = 10 goings

Numbers of riser = 10 + 1 = 11

Size of riser =  $\frac{1980}{11} = 180$  mm

$2R + G = (700\text{mm} + 550\text{mm})/2 = 625\text{mm}$

$G = 625 - 2R = 625 - 2 \cdot (180)$

$$G = 625 - 360 = 265$$

$$\text{Effective horizontal length} = L_a + 0.3 (L_{b1} + L_{b2})$$

Where  $L_a$  = Is the length of stair including landing

$L_{b1}$  and  $L_{b2}$  = width of supports (width of beam)

$$= 8.47 + 0.5(0.4 + 0.4) = 7.176 \text{ m}$$

$$\approx 7176 \text{ mm}$$

Length of going of flight = Number of goings \* Size of going

$$= 10 * 265 = 2650 \text{ mm}$$

Centre to center length of going of flight =

$$2650 + 0.5 (400 + 400) = 3050$$

$$\text{Length of flight} = \sqrt{(1980)^2 + (3050)^2}$$

$$= 3920400 + 9302500 = 13222900$$

$$= 3636.33$$

$$\approx 3.63 \text{ m}$$

Slope =  $\tan^{-1} \alpha$  = (Riser of flight): (horizontal distance)

$$\tan^{-1} \alpha = \left(\frac{1980}{3050}\right) = 0.6491$$

$$\alpha = 32.9^\circ$$

Minimum pitch =  $25^\circ$  and maximum pitch =  $45^\circ$

Depth of waist = (Effective horizontal distance) / (26)

$$= 117.30 \text{ mm}$$

$$= 120 \text{ mm}$$

Thickness = effective depth + (main bar/2) + cover

$$= 120 \text{ mm} + (16/2) + 25 \text{ mm}$$

$$= 153 = 150 \text{ mm}$$

### Dead load calculation

Out of landing

Self - weight = 1.4 thickness of stair slab .....

$$\sin \alpha = (ac/262) = ac = 265 \sin \alpha$$

$$= 265 \sin 32 = 143.94 \text{ mm}$$

Thickness of stair including finishes=Thickness of waist calculated thickness of step+thickness of finishes

$$= 150 + (143.9/2) + 3$$

$$= 224.95 \text{ mm}$$

Self - Weight = 1.4\* width of landing \*Thickness of landing\* unit of concrete) \*0.5

$$= 1.4*4*2.06*25) *0.5$$

$$=144.2 \text{ KN}$$

Impose load =

$$= (1.6*4*2.06*3) *0.5$$

$$=19.776$$

Total design load= 163.976

Total load on Span length = 163.97+184.006

Self-weight = 1,4 \*0,22495\*3,63\*4\*25kn/m<sup>3</sup>

$$=114,31\text{kN}$$

Imposed load =1,6\* length of flight\*width of flight\*imposed load from the table 1of BS 6399:1-1997

$$\text{Imposed load} = 1,6 *3,63*4*3=69,696$$

Total design loads on stairs slab =design dead load +design live load

$$114,31 + 69.696 = 184,006$$

### **Landing**

Self-weight of landing = (1,4 \*width of landing thickness of landing \*unit of concrete) \*0,5

$$(1,4*4*2,06*25) *0,5=144.2$$

$$\text{Imposed load} = (1,6*4*2,06*3) *0,5=19,776$$

Total design load =163,976

Total load on span length=163,97+184,006

$$W = 347.976$$

$$M_{\max} = wl/10 = (347.976*176):10 = 249.49\text{KN}$$

$$M=0 = 0*RA+163.97*2.06+184.006*(4126+1525)-RB*(4126+3050) =0$$

$$= 522.27611*(5.651)-RB*(7.176)$$

$$2951.38-7.176RB = 0$$

$$7.176RB=2951.38$$

$$RB = (2951.38/7.176) = KN$$

$$RA + RB = 347.976$$

$$RA + 112.21 = 347.976$$

$$RA = 347.976 - 112.21$$

$$RA = 235.76$$

$$\text{Shearforce at } B = 112.21$$

$$\text{SF at } D = RB - FD = \frac{1}{2} - 184.006 = -71.79$$

$$\text{SF at } C = RB - FC = 112.21 - 163.97 = -51.76$$

$$\text{SF at } A = RB - FA = 112.21 - 184.006 - 163.97 = -235,766$$

$$\text{Shearforce at } RB = 112.21$$

Area of steel is found by using chart

$100 A_s/bd = \text{value from chart.}$

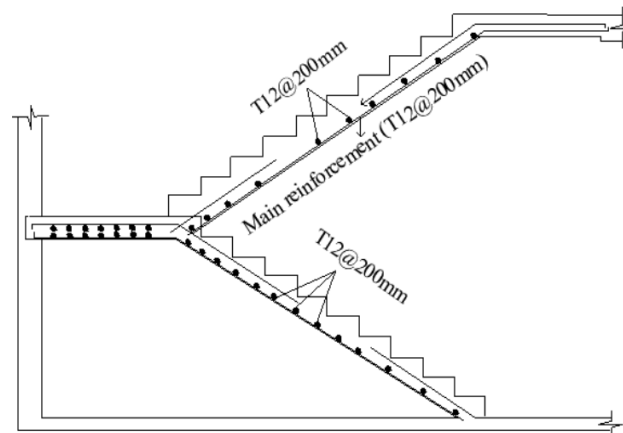

Figure 4.11: Detailing of stair

#### 4.6. Design of ramp

Given Data:

- Ramp Length (L) = 3764 cm = 37.64 m

- Ramp Width (W) = 1200 cm = 12.00 m

- Height to be covered ( $\Delta h$ ) = 4 m

Calculate the Slope of the Ramp

We need to calculate the slope or gradient of the ramp. The slope (S) can be calculated using the formula:

$$s = \frac{\Delta h}{l} = \frac{4}{37,64} = 0,1063$$

**convert the slope to percentage**

$$S\% = 0,1063 * 100 = 10,63\%$$

The slope of the ramp is 10.63%, which is acceptable for vehicle ramps (typically between 8% and 12%).

**Dead load calculation**

- Material: Assume reinforced concrete with a unit weight of 24 kN/m<sup>3</sup>.
- Ramp Thickness (t): Let's assume a slab thickness of 0.2 m (20 cm)

The dead load (self-weight of the ramp) per square meter is calculated as:

**Dead load**=thickness\*unit weight=0,2\*24=4,8 KN/m<sup>2</sup>

**Live load** =For vehicle ramps, a live load of 5 kN/m<sup>2</sup> (typical for parking structures) will be assumed.

**Total load**

The total load (w) on the ramp will be the sum of the dead load and live load:

$$W = \text{dead load} + \text{live load} = 4,8\text{KN}/\text{m}^2 + 5\text{kN}/\text{m}^2 = 9\text{KN}/\text{m}^2$$

**Moment Calculation:**

To calculate the bending moment, we need to know the span or support conditions. For simplicity, we'll assume a simply supported ramp\*\* with a span equal to its width (W = 12 m).

The bending moment at the center of the span can be calculated using the formula for a

simply supported beam:  $M = \frac{w * l^2}{8} = \frac{9,8 * 12^2}{8} = \frac{9,8 * 144}{8} = 176,4\text{KNm}$

$$A_s = \frac{M}{f_y * d}$$

Where:

- M = bending moment = 176.4 kNm

- $f_y$  = yield strength of steel (assume 500 MPa or 500 N/mm<sup>2</sup>)
- $d$  = effective depth (assume an effective depth of 160 mm = 0.16 m for a 0.2 m slab)

First, convert the moment to Nmm:

$$M = 176.4 * 10^6 \text{ Nmm}$$

Now, calculate the area of steel:

$$A_s = \frac{176,4 * 10^6}{500 * 160} = \frac{176,4 * 10^6}{80000} = 2205$$

$A_{sprov} = 2513; 8T20$

Shear force

$$V = \frac{w * l}{2} = \frac{9,8 \text{KN/m} * 12 \text{m}}{2} = 58,8 \text{KN}$$

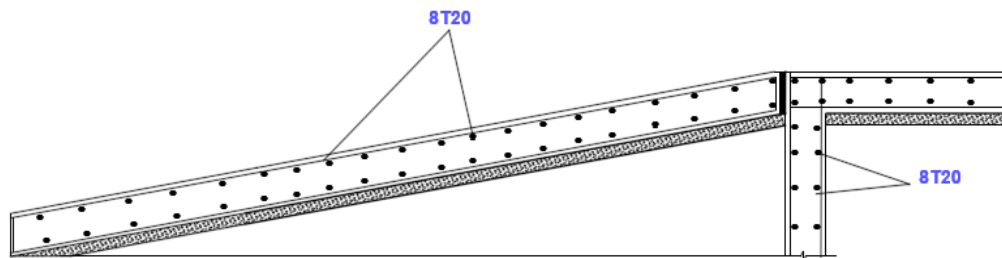

Figure 4.12: Detailing of ramp

Check the concrete section's capacity to resist this shear force, and if necessary, design shear reinforcement (stirrups) accordingly.

Deflection Check:

For serviceability, you need to check deflection. Maximum deflection for the ramp should be within the permissible limits ( $L/240$  for live loads), where  $(L)$  is the span.

## **CHAPTER 5.CONCLUSION AND RECOMENDATIONS**

### **5.1. Conclusion**

The redevelopment project of Nyabugogo Station in Kigali, focusing on the design and construction of a modern G+3 commercial building using reinforced concrete, represents a significant step in improving urban transport infrastructure in Rwanda. The study demonstrated that the use of reinforced concrete provides a durable and efficient solution, especially in challenging areas like Nyabugogo, which is characterized by swampy conditions.

The integration of a multifunctional building with commercial spaces, offices, and restaurants not only enhances the functionality of the station but also stimulates the local economy. The project significantly improves the experience for travelers and the services provided, while addressing the growing mobility needs of an expanding city like Kigali. Additionally, the use of modern construction techniques ensured the building's safety and longevity, meeting current construction standards.

The main challenges encountered, particularly those related to the foundation in a swampy area, were overcome through in-depth geotechnical studies and appropriate reinforcement techniques. This highlights the importance of site analysis in similar projects. In summary, this project represents a major advancement for the development of Kigali's urban infrastructure, combining innovation, sustainability, and efficiency.

### **5.2. Recommendations**

It is recommended to consider the future expansion of parking facilities to accommodate the ongoing increase in the number of travelers. The integration of green technologies, such as solar panels or rainwater harvesting systems, could also enhance the building's sustainability and reduce its environmental impact. Furthermore, flexibility in design will allow for adaptation to the city's future needs.

Adopting more modern construction techniques, such as prefabrication of concrete elements, would be beneficial to speed up project timelines and minimize disruptions at the station site. Given the swampy conditions around Nyabugogo, it is essential to implement regular monitoring of the foundation to ensure the building maintains its stability and durability in the long term.



## REFERENCES

British Standards Institution. (1996). *BS 6399-1: Loading for Buildings – Part 1: Code of Practice for Dead and Imposed Loads*. BSI.

American Concrete Institute. (2019). *ACI 318-19: Building Code Requirements for Structural Concrete and Commentary*. ACI.

Eurocode. (2004). *EN 1997-1: Eurocode 7 – Geotechnical Design – Part 1: General Rules*. European Committee for Standardization.

Mosley, W.H., Bungey, J.H., & Hulse, R. (2012). *Reinforced Concrete Design: To Eurocode 2*. Palgrave Macmillan.

National Building Code. (2021). *International Building Code (IBC)*. International Code Council.

Neville, A.M. (2011). *Properties of Concrete*. Pearson Education.

British Standards Institution. (1997). *BS 8110-1: Structural Use of Concrete – Part 1: Code of Practice for Design and Construction*. BSI.

British Standards Institution. (2005). *BS 4449: Specification for Carbon Steel Bars for the Reinforcement of Concrete*. BSI.

Terzaghi, K., Peck, R.B., & Mesri, G. (1996). *Soil Mechanics in Engineering Practice* (3rd ed.). Wiley.

Park, R., & Paulay, T. (1975). *Reinforced Concrete Structures*. Wiley.

Eurocode. (2004). *EN 1991-1-4: Eurocode 1: Actions on Structures – Part 1-4: General Actions – Wind Actions*. European Committee for Standardization.

Hibbeler, R.C. (2017). *Structural Analysis* (10th ed.). Pearson.

## APPENDICES

### Appendix 1) Basic span/effective depth ratio for rectangular or flanged beams

**Table 3.9 — Basic span/effective depth ratio for rectangular or flanged beams**

Support conditions	Rectangular section	Flanged beams with $\frac{b_w}{b} \leq 0.3$
Cantilever	7	5.6
Simply supported	20	16.0
Continuous	26	20.8

### Appendix 2) Values of the coefficient $\beta$

**BS 8110-1:1997**

---

---

**Table 3.22 — Values of the coefficient  $\beta$**

$\frac{N}{bhf_{cu}}$	0	0.1	0.2	0.3	0.4	0.5	$\geq 0.6$
$\beta$	1.00	0.88	0.77	0.65	0.53	0.42	0.30

### Appendix 3) shear coefficient for uniformly loaded rectangular panel supported on four side

BS 8110-1:1997

Table 3.15 — Shear force coefficient for uniformly loaded rectangular panels supported on four sides with provision for torsion at corners

Type of panel and location	$\beta_{vx}$ for values of $l_y/l_x$								$\beta_{vy}$
	1.0	1.1	1.2	1.3	1.4	1.5	1.75	2.0	
<b>Four edges continuous</b>									
Continuous edge	0.33	0.36	0.39	0.41	0.43	0.45	0.48	0.50	0.33
<b>One short edge discontinuous</b>									
Continuous edge	0.36	0.39	0.42	0.44	0.45	0.47	0.50	0.52	0.36
Discontinuous edge	—	—	—	—	—	—	—	—	0.24
<b>One long edge discontinuous</b>									
Continuous edge	0.36	0.40	0.44	0.47	0.49	0.51	0.55	0.59	0.36
Discontinuous edge	0.24	0.27	0.29	0.31	0.32	0.34	0.36	0.38	—
<b>Two adjacent edges discontinuous</b>									
Continuous edge	0.40	0.44	0.47	0.50	0.52	0.54	0.57	0.60	0.40
Discontinuous edge	0.26	0.29	0.31	0.33	0.34	0.35	0.38	0.40	0.26
<b>Two short edges discontinuous</b>									
Continuous edge	0.40	0.43	0.45	0.47	0.48	0.49	0.52	0.54	—
Discontinuous edge	—	—	—	—	—	—	—	—	0.26
<b>Two long edges discontinuous</b>									
Continuous edge	—	—	—	—	—	—	—	—	0.40
Discontinuous edge	0.26	0.30	0.33	0.36	0.38	0.40	0.44	0.47	—
<b>Three edges discontinuous (one long edge discontinuous)</b>									
Continuous edge	0.45	0.48	0.51	0.53	0.55	0.57	0.60	0.63	—
Discontinuous edge	0.30	0.32	0.34	0.35	0.36	0.37	0.39	0.41	0.29
<b>Three edges discontinuous (one short edge discontinuous)</b>									
Continuous edge	—	—	—	—	—	—	—	—	0.45
Discontinuous edge	0.29	0.33	0.36	0.38	0.40	0.42	0.45	0.48	0.30
<b>Four edges discontinuous</b>									
Discontinuous edge	0.33	0.36	0.39	0.41	0.43	0.45	0.48	0.50	0.33

#### 3.5.4 Resistance moment of solid slabs

The design ultimate resistance moment of a cross-section of a solid slab may be determined by the methods given in 3.4.4 for beams.

## Appendix 4) Bending moment coefficient for uniformly loaded rectangular panel supported on four side

BS 8110-1:1997

Table 3.14 — Bending moment coefficients for rectangular panels supported on four sides with provision for torsion at corners

Type of panel and moments considered	Short span coefficients, $\beta_{sx}$								Long span coefficients, $\beta_{sy}$ for all values of $l_y/l_x$
	Values of $l_y/l_x$								
	1.0	1.1	1.2	1.3	1.4	1.5	1.75	2.0	
<b>Interior panels</b>									
Negative moment at continuous edge	0.031	0.037	0.042	0.046	0.050	0.053	0.059	0.063	0.032
Positive moment at mid-span	0.024	0.028	0.032	0.035	0.037	0.040	0.044	0.048	0.024
<b>One short edge discontinuous</b>									
Negative moment at continuous edge	0.039	0.044	0.048	0.052	0.055	0.058	0.063	0.067	0.037
Positive moment at mid-span	0.029	0.033	0.036	0.039	0.041	0.043	0.047	0.050	0.028
<b>One long edge discontinuous</b>									
Negative moment at continuous edge	0.039	0.049	0.056	0.062	0.068	0.073	0.082	0.089	0.037
Positive moment at mid-span	0.030	0.036	0.042	0.047	0.051	0.055	0.062	0.067	0.028
<b>Two adjacent edges discontinuous</b>									
Negative moment at continuous edge	0.047	0.056	0.063	0.069	0.074	0.078	0.087	0.093	0.045
Positive moment at mid-span	0.036	0.042	0.047	0.051	0.055	0.059	0.065	0.070	0.034
<b>Two short edges discontinuous</b>									
Negative moment at continuous edge	0.046	0.050	0.054	0.057	0.060	0.062	0.067	0.070	—
Positive moment at mid-span	0.034	0.038	0.040	0.043	0.045	0.047	0.050	0.053	0.034
<b>Two long edges discontinuous</b>									
Negative moment at continuous edge	—	—	—	—	—	—	—	—	0.045
Positive moment at mid-span	0.034	0.046	0.056	0.065	0.072	0.078	0.091	0.100	0.034
<b>Three edges discontinuous (one long edge continuous)</b>									
Negative moment at continuous edge	0.057	0.065	0.071	0.076	0.081	0.084	0.092	0.098	—
Positive moment at mid-span	0.043	0.048	0.053	0.057	0.060	0.063	0.069	0.074	0.044
<b>Three edges discontinuous (one short edge continuous)</b>									
Negative moment at continuous edge	—	—	—	—	—	—	—	—	0.058
Positive moment at mid-span	0.042	0.054	0.063	0.071	0.078	0.084	0.096	0.105	0.044
<b>Four edges discontinuous</b>									
Positive moment at mid-span	0.055	0.065	0.074	0.081	0.087	0.092	0.103	0.111	0.056

## Appendix 5) Areas of groups of bars

**Table 4.1** Areas of groups of bars

Diameter (mm)	Number of bars in groups							
	1	2	3	4	5	6	7	8
6	28	56	84	113	141	169	197	226
8	50	100	150	201	251	301	351	402
10	78	157	235	314	392	471	549	628
12	113	226	339	452	565	678	791	904
16	201	402	603	804	1005	1206	1407	1608
20	314	628	942	1256	1570	1884	2199	2513
25	490	981	1472	1963	2454	2945	3436	3927
32	804	1608	2412	3216	4021	4825	5629	6433

## Appendix 6) Bar spacing data

**Table 8.2** Bar spacing data

Diameter (mm)	Area (mm <sup>2</sup> ) for spacing mm												
	s=80	100	120	140	150	160	180	200	220	240	260	280	300
6	350	282	235	201	188	176	157	141	128	117	113	100	94
8	628	502	418	359	335	314	279	251	228	209	201	179	167
10	981	785	654	560	523	490	436	392	356	327	314	280	261
12	1413	1130	942	807	753	706	628	565	514	471	452	403	376
16	2513	2010	1675	1436	1340	1256	1117	1005	913	837	804	718	670

Spacing *s* in millimetres.

## Appendix 7) Structural plans



# Appendix 8) Sections

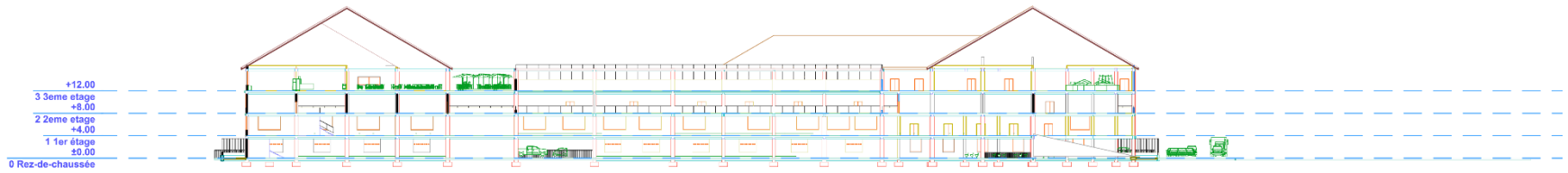
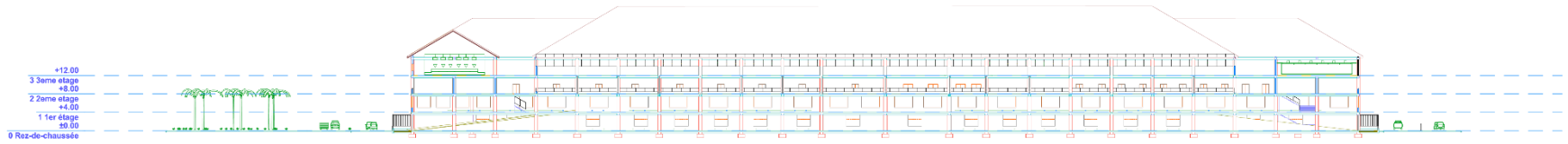
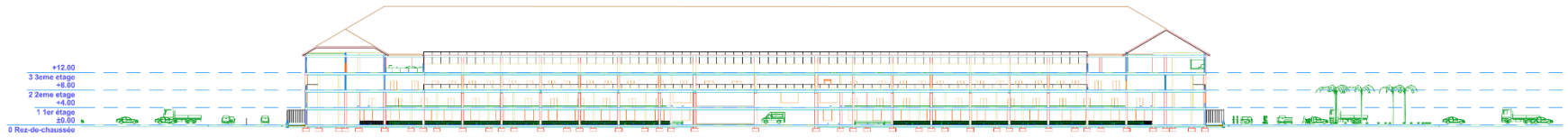

# Appendix 9) Ground floor

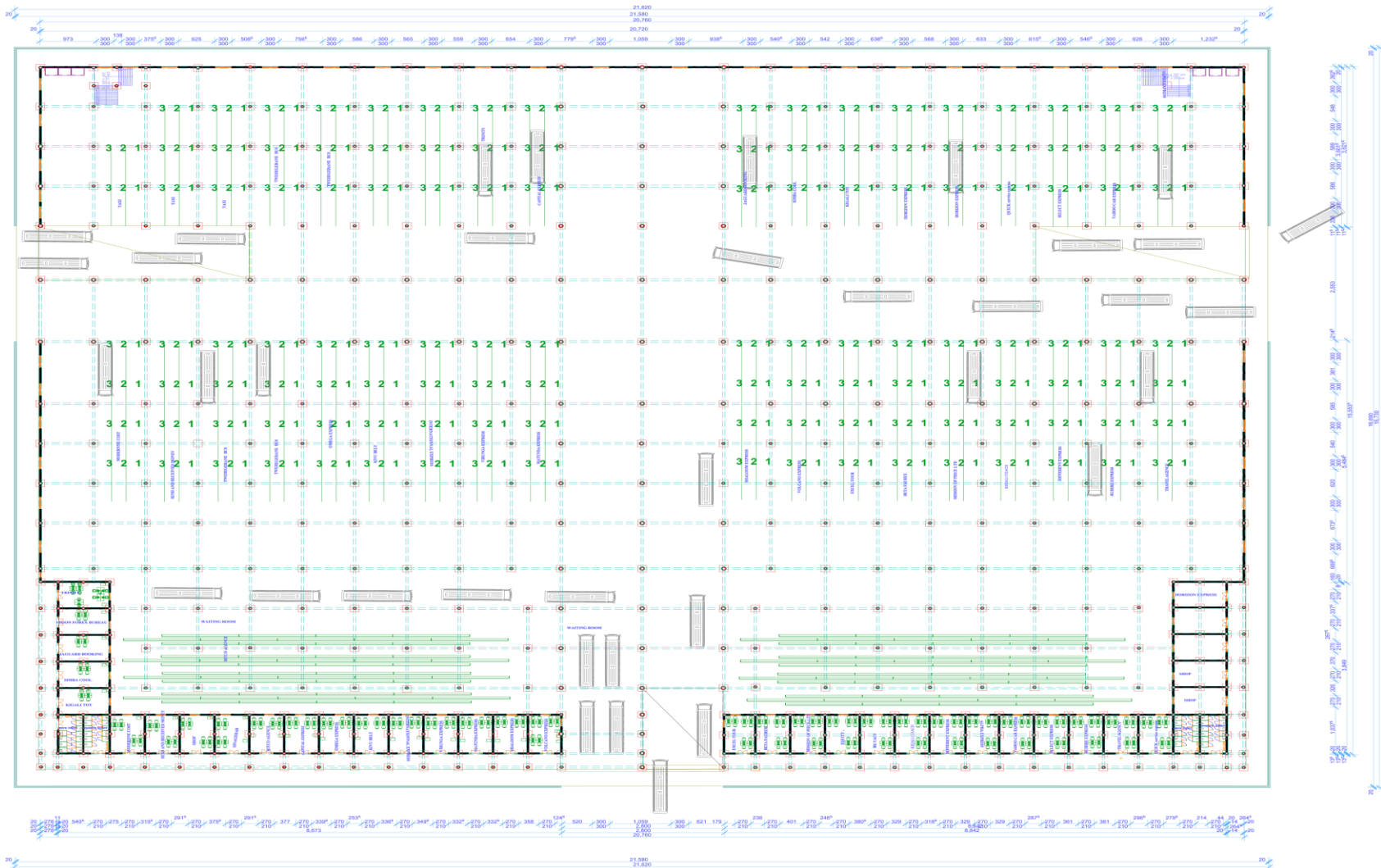



# Appendix 10) First floor

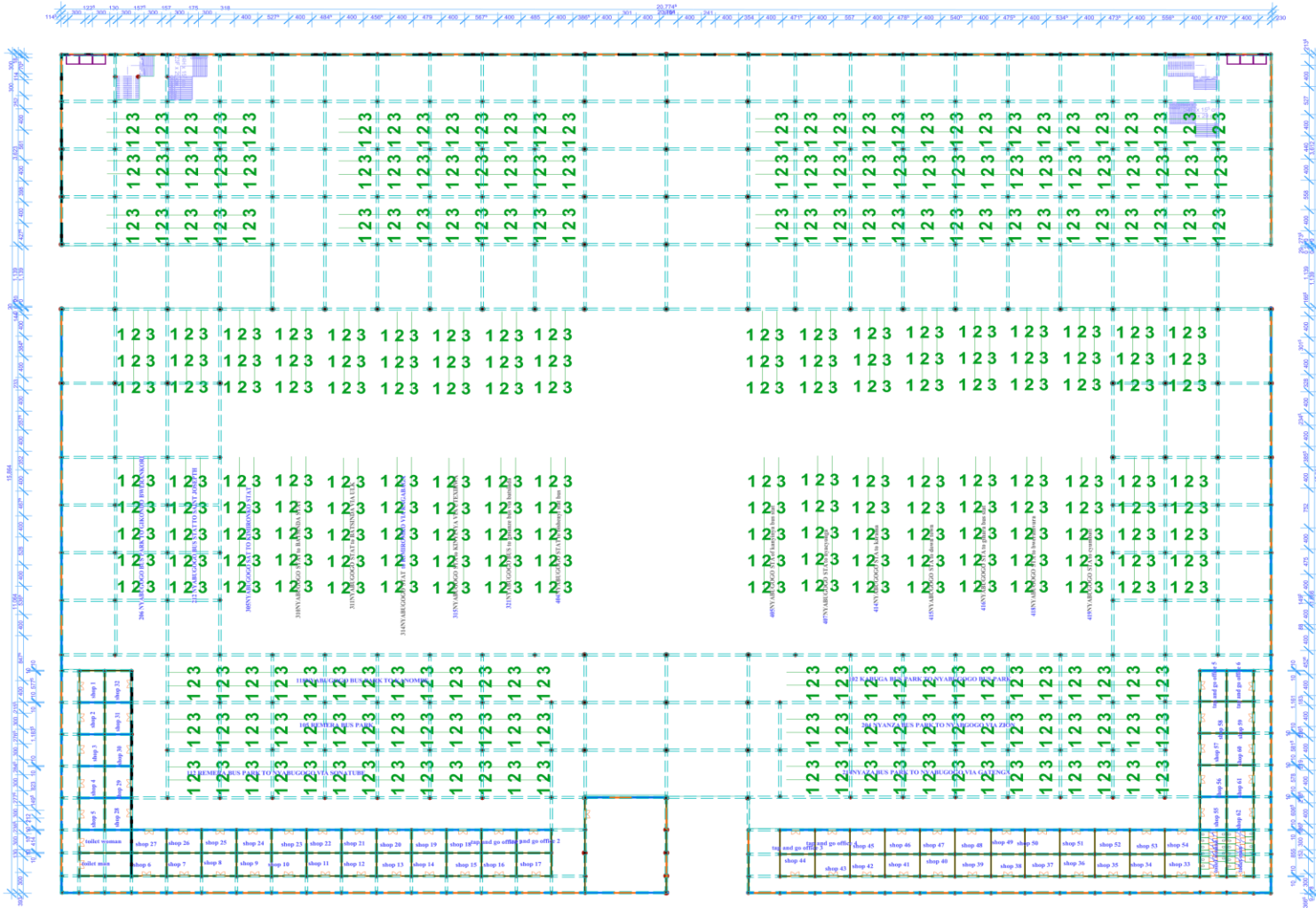

# Appendix 11) Second floor

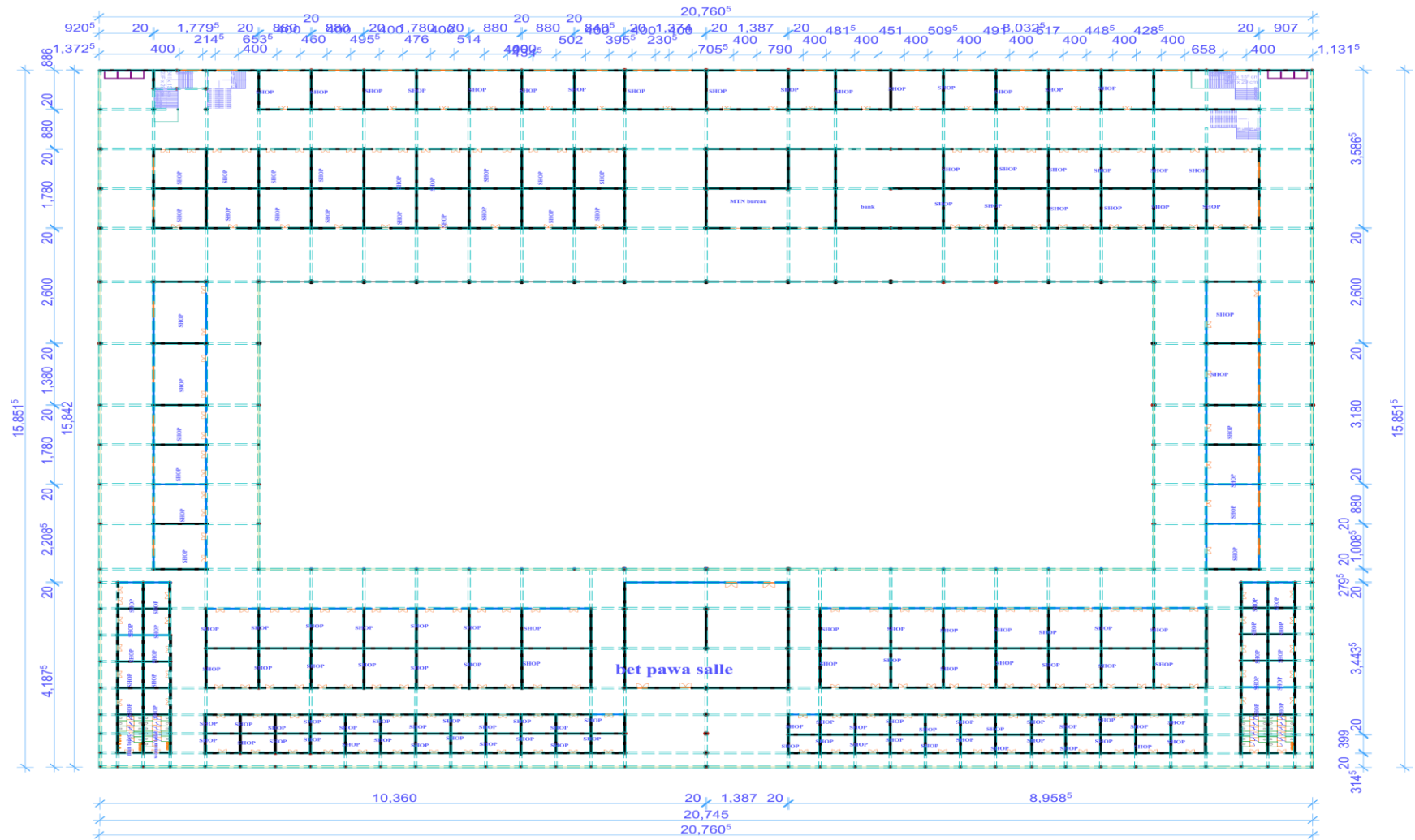

# Appendix 12) Third Floor

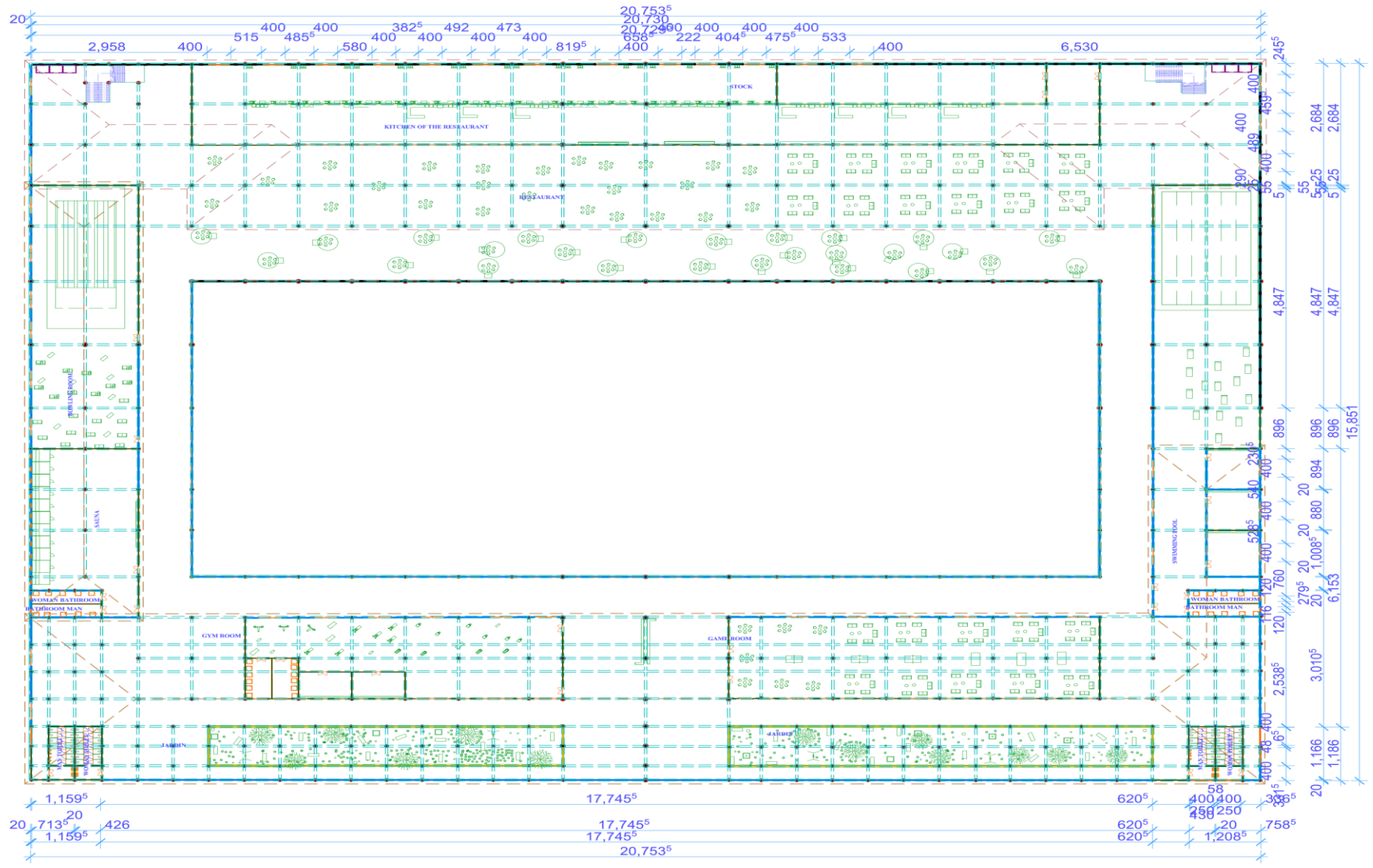

## Appendix 13) Views

Front view



Right view



Back view

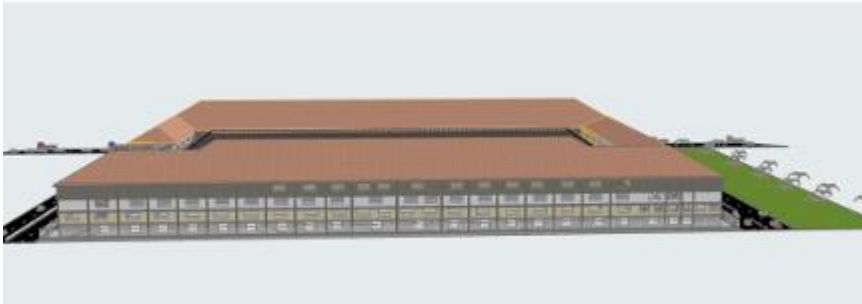

Lift view

